



**BRIGHTTEK**  
**BRIGHTTEK (EUROPE) LIMITED**

*Brighten Up The World With LED!*



ISO/TS 16949:2009



BS EN ISO 14001:2004



QC 080000 IECQ HSPM

## PRODUCT DATASHEET



- ▶ DC Input Photo Coupler
- ▶ SMD8
- ▶ High Speed Transistor  
1Mbit/s

**TD4502(S)(T1)-GV**  
**TD4503(S)(T1)-GV**



Release Date: 06 September 2024 Version: A01



## TD450X(S) Series



### DESCRIPTION:

The TD450X(S) series combine an AlGaAs infrared emitting diode as the emitter which is optically coupled to a silicon high speed photo transistor in a plastic DIP8 package with SMD8 lead forming option. A separate design between photodiode and transistor reduces the base-collector capacitance of the input transistor which improves the speed by several orders of magnitude over conventional phototransistor optocouplers.

### FEATURES:

- High isolation 5000 Vrms
- DC input with transistor output
- Operating temperature range -55°C to +100°C
- REACH & RoHS compliance
- MSL class 1
- Regulatory Approvals:
  - UL - UL1577
  - VDE - EN60747-5-5 (VDE0884-5)
  - CQC - GB4943.1, GB8898
  - cUL - CSA Component Acceptance Service Notice 5A

### APPLICATIONS:

- Line receivers
- Telecommunication equipment
- Out interface to CMOS-LSTTL-TTL
- Wide bandwidth analog coupling
- Pulse transformer replacement
- Computer-peripheral interface



Partner with: LIGHTNING

**NAMING & ORDERING INFORMATION:**

---

Naming Information:

<b>TD4502 (S) (T1) - G V</b> <b>TD4503 (S) (T1) - G V</b>	
<b>TD4502</b> <b>TD4503</b>	Part Number
<b>S</b>	Lead Form Option: SMD8
<b>T1</b>	Selection: Tape and Reel Option (T1(default)/T2)
<b>G</b>	Green Option
<b>V</b>	VDE Option

Ordering Information:

<b>TD4502(S)(T1)-GV</b> <b>TD4503(S)(T1)-GV</b>
--

Version No.	Original Release Date
Rev: A01	09/09/2022

## SCHEMATIC DIAGRAM & MARKING:

Schematic Diagram:

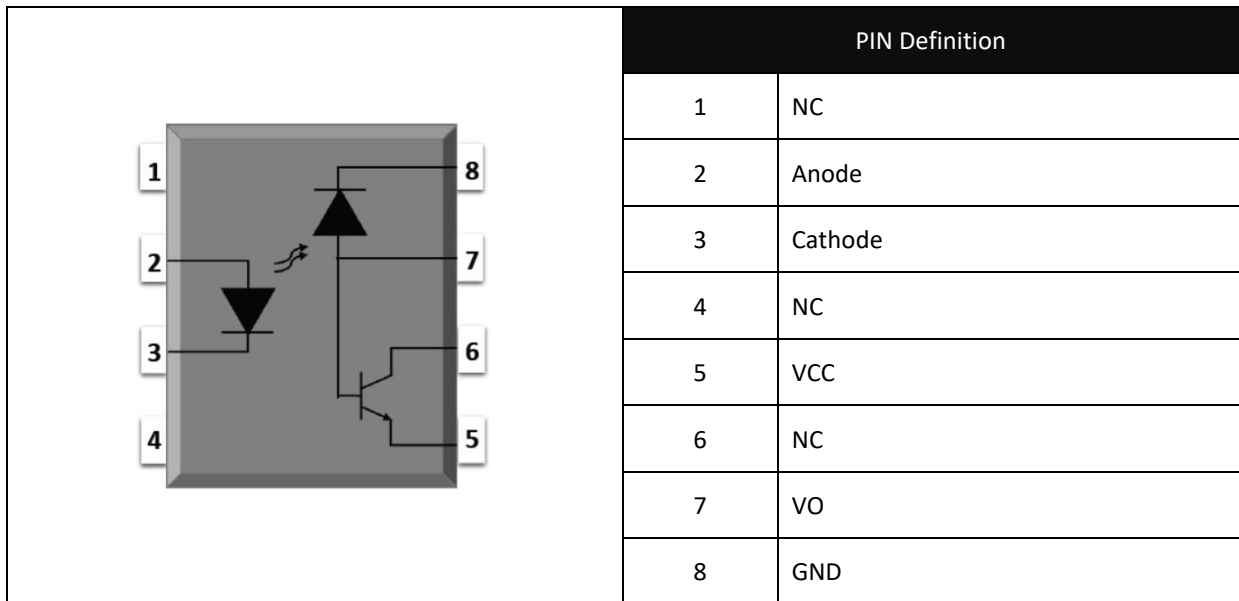

Marking Information:

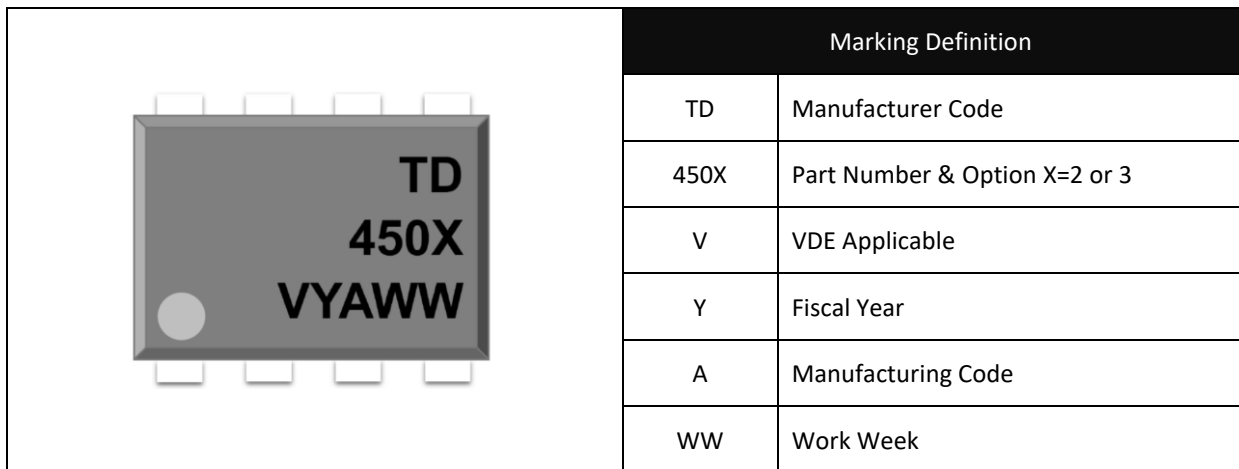

Labelling Information:



This product is manufactured, tested, and packed by



## ABSOLUTE CHARACTERISTICS:

### Absolute Maximum Ratings:

Parameter	Symbol	Ratings	Unit
INPUT			
Forward Current	$I_F$	25	mA
Peak Forward Current	$I_{FP}$	50 * <sup>1</sup>	mA
Peak Transient Current	$I_{F(trans)}$	1 * <sup>2</sup>	A
Reverse Voltage	$V_R$	5	V
Input Power Dissipation	$P_I$	100	mW
OUTPUT			
Supply Voltage	$V_{CC}$	-0.5~30	V
Output Voltage	$V_O$	-0.5~20	V
Output Current	$I_O$	50	mA
Emitter-Base Reverse Voltage	$V_{EBR}$	5	V
Base Current	$I_B$	5	mA
Output Power Dissipation	$P_O$	100	mW
COMMON			
Total Power Dissipation	$P_{tot}$	200	mW
Isolation Voltage	$V_{ISO}$	5000 * <sup>3</sup>	Vrms
Operating Temperature	$T_{opr}$	-55~+100	°C
Storage Temperature	$T_{stg}$	-55~+150	°C
Soldering Temperature	$T_{sol}$	260 * <sup>4</sup>	°C

\*1. 50% duty, 1ms P.W

\*2.  $\leq 1\mu s$  P.W, 300pps

\*3. AC for 1 minute, R.H.=40~60%

\*4. for 10 seconds

## ELECTRICAL CHARACTERISTICS:

### Electrical Optical Characteristics:

Parameter	Symbol	Values			Unit	Test Condition	
		Min.	Typ.	Max.			
INPUT (at T <sub>a</sub> =0 to 70°C, unless specified otherwise)							
Forward Voltage	V <sub>F</sub>	---	1.45	1.8	V	I <sub>F</sub> =16mA	
Reverse Current	I <sub>R</sub>	---	---	10	μA	V <sub>R</sub> =5V	
Input Capacitance	C <sub>IN</sub>	---	60	---	pF	V=0, f=1MHz	
OUTPUT (at T <sub>a</sub> =0 to 70°C, unless specified otherwise)							
High Level Supply Current	I <sub>CCH</sub>	---	0.01	1	μA	I <sub>F</sub> =0mA, V <sub>O</sub> =OPEN V <sub>CC</sub> =15V, T <sub>a</sub> =25°C	
		---	---	2	μA	I <sub>F</sub> =0mA, V <sub>O</sub> =OPEN V <sub>CC</sub> =15V	
Low Level Supply Current	I <sub>CCL</sub>	---	200	---	μA	I <sub>F</sub> =16mA V <sub>O</sub> =OPEN V <sub>CC</sub> =15V	
Logic High Output Current	I <sub>OH</sub>	---	0.001	0.5	μA	I <sub>F</sub> =0mA, T <sub>a</sub> =25°C V <sub>O</sub> =V <sub>CC</sub> =5.5V	
		---	0.01	1	μA	I <sub>F</sub> =0mA, T <sub>a</sub> =25°C V <sub>O</sub> =V <sub>CC</sub> =15V	
		---	---	50	μA	I <sub>F</sub> =0mA V <sub>O</sub> =V <sub>CC</sub> =15V	
TRANSFER CHARACTERISTICS (at T <sub>a</sub> =0 to 70°C, unless specified otherwise)							
Current Transfer Ratio	TD4502	CTR	19	---	50	μA	I <sub>F</sub> =16mA, V <sub>O</sub> =0.4V V <sub>CC</sub> =4.5V, T <sub>a</sub> =25°C
			15	---	---		I <sub>F</sub> =16mA, V <sub>O</sub> =0.5V V <sub>CC</sub> =4.5V
	TD4503		19	---	50		I <sub>F</sub> =16mA, V <sub>O</sub> =0.4V V <sub>CC</sub> =4.5V, T <sub>a</sub> =25°C
			15	---	---		I <sub>F</sub> =16mA, V <sub>O</sub> =0.5V V <sub>CC</sub> =4.5V
Logic Output Voltage	TD4502	V <sub>OL</sub>	---	0.25	0.4	μA	I <sub>F</sub> =16mA V <sub>CC</sub> =4.5V I <sub>O</sub> =3mA T <sub>a</sub> =25°C
			---	---	0.5		I <sub>F</sub> =16mA V <sub>CC</sub> =4.5V I <sub>O</sub> =2.4mA
	TD4503		---	0.25	0.4		I <sub>F</sub> =16mA V <sub>CC</sub> =4.5V I <sub>O</sub> =3mA T <sub>a</sub> =25°C
			---	---	0.5		I <sub>F</sub> =16mA V <sub>CC</sub> =4.5V I <sub>O</sub> =2.4mA
Isolation Resistance	R <sub>iso</sub>	10 <sup>12</sup>	10 <sup>14</sup>	---	Ω	DC=500V, 40 ~ 60% R.H.	
Floating Capacitance	C <sub>IO</sub>	---	0.3	1	pF	V=0, f=1MHz	

## ELECTRICAL CHARACTERISTICS:

Electrical Optical Characteristics:

Parameter	Symbol	Values			Unit	Test Condition	
		Min.	Typ.	Max.			
SWITCHING CHARACTERISTICS (at $T_a=0$ to $70^\circ\text{C}$ , $I_F=16\text{mA}$ , $V_{CC}=5\text{V}$ , unless specified otherwise)							
Propagation Delay Time to Logic Low	TD4502	TPHL	---	0.35	0.8	$\mu\text{s}$	$R_L=1.9\text{k}\Omega$ $T_a=25^\circ\text{C}$
			---	---	1.0		$R_L=1.9\text{k}\Omega$
	TD4503		---	0.35	0.8		$R_L=1.9\text{k}\Omega$ $T_a=25^\circ\text{C}$
			---	---	1.0		$R_L=1.9\text{k}\Omega$
Propagation Delay Time to Logic High	TD4502	TPLH	---	0.3	0.8	$\mu\text{s}$	$R_L=1.9\text{k}\Omega$ $T_a=25^\circ\text{C}$
			---	---	1.0		$R_L=1.9\text{k}\Omega$
	TD4503		---	0.3	0.8		$R_L=1.9\text{k}\Omega$ $T_a=25^\circ\text{C}$
			---	---	1.0		$R_L=1.9\text{k}\Omega$
Common Mode Transient Immunity at Logic High	TD4502	CM <sub>H</sub>	1000	---	---	$\text{V}/\mu\text{s}$	$I_F=0\text{mA}$ $V_{CM}=10\text{V}_{pp}$ $R_L=1.9\text{k}\Omega$ $T_a=25^\circ\text{C}$
	TD4503		15000	20000	---		$I_F=0\text{mA}$ $R_L=1.9\text{k}\Omega$ $V_{CM}=1500\text{V}_{pp}$ $T_a=25^\circ\text{C}$
Common Mode Transient Immunity at Logic Low	TD4502	CM <sub>L</sub>	1000	---	---	$\text{V}/\mu\text{s}$	$I_F=16\text{mA}$ $R_L=1.9\text{k}\Omega$ $V_{CM}=10\text{V}_{pp}$ $T=25^\circ\text{C}$
	TD4503		15000	20000	---		$I_F=16\text{mA}$ $R_L=1.9\text{k}\Omega$ $V_{CM}=1500\text{V}_{pp}$ $T_a=25^\circ\text{C}$

## CHARACTERISTIC CURVES:

Forward Current v.s. Forward Voltage

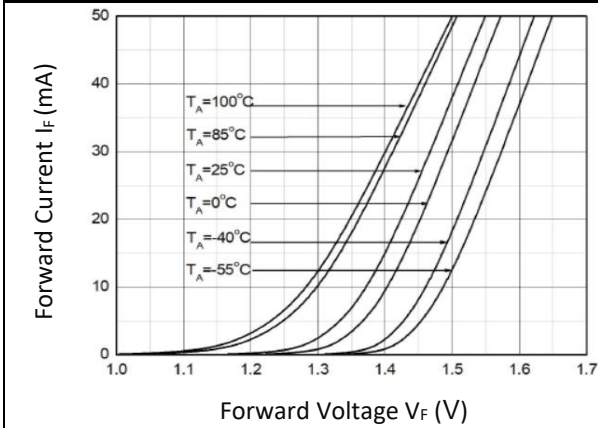

Forward Voltage v.s. Ambient Temp.

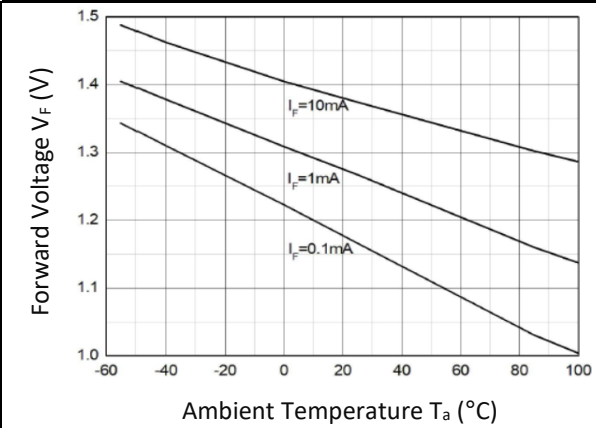

Normalized Current Transfer Ratio v.s. Forward Current

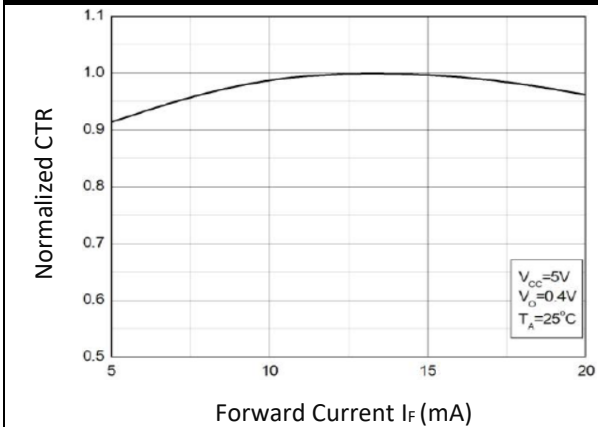

Normalized Current Transfer Ratio v.s. Ambient Temperature

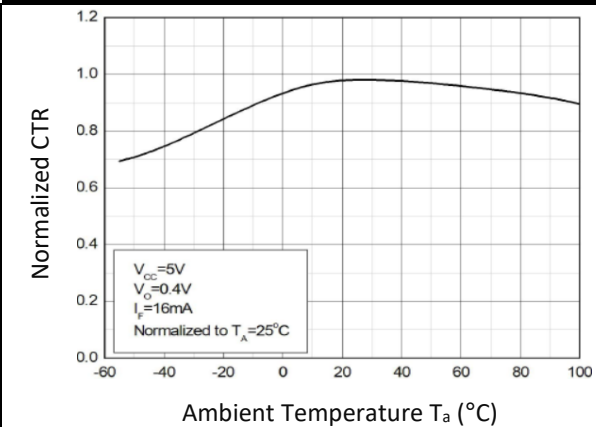

Output Current v.s. Output Voltage

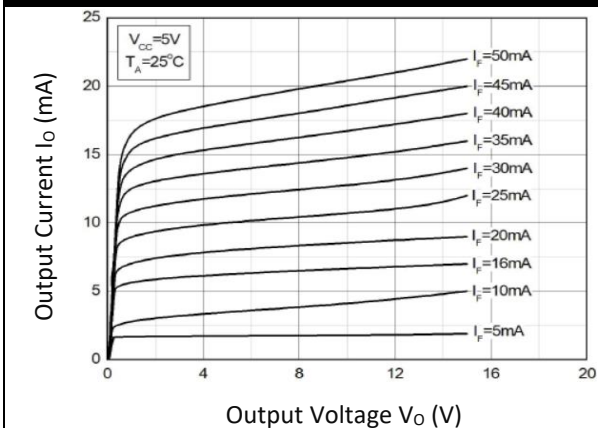

Output Current v.s. Output Voltage

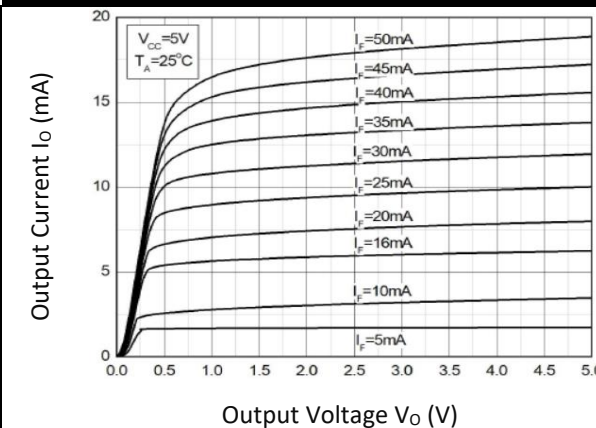

## CHARACTERISTIC CURVES:

Output Current v.s. Forward Current

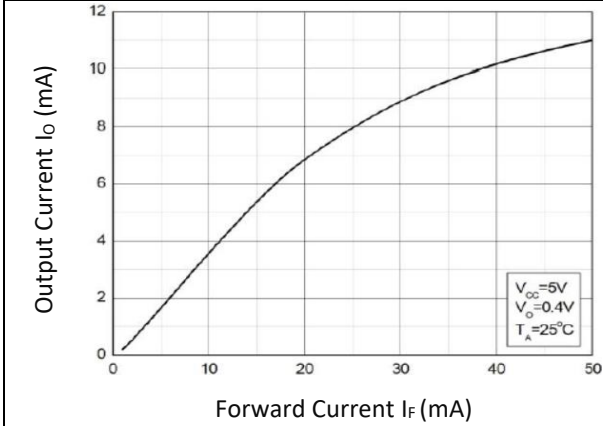

High Level Output Current v.s. Ambient Temperature

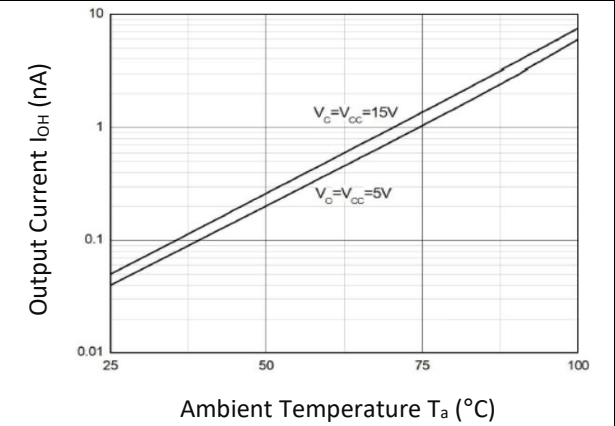

Switching Time v.s. Load Resistance

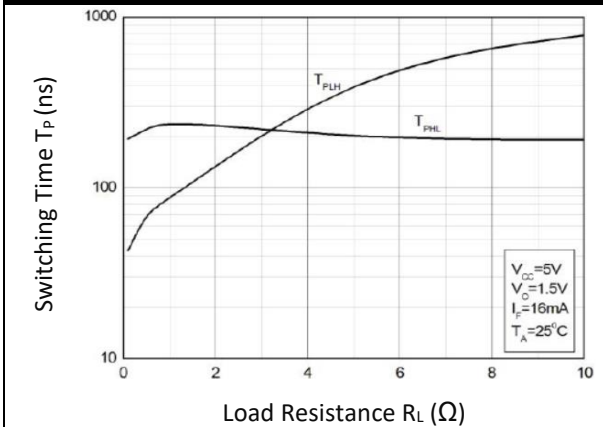

Switching Time v.s. Load Resistance

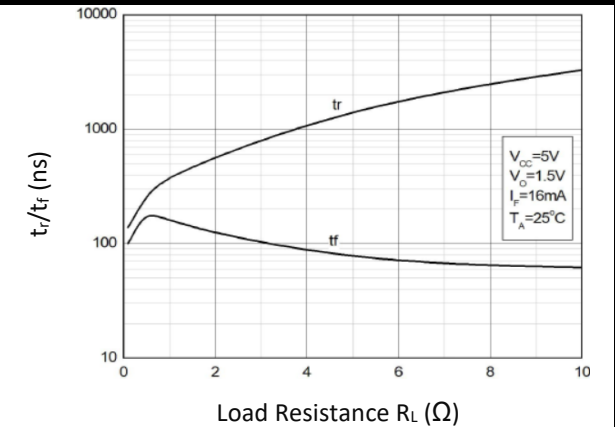

Switching Time v.s. Ambient Temperature

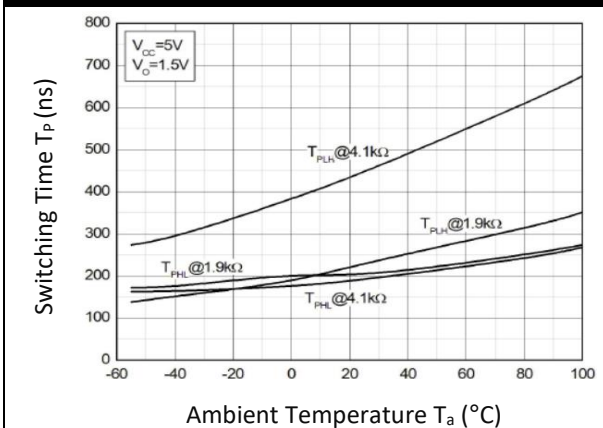

Switching Time v.s. Forward Current

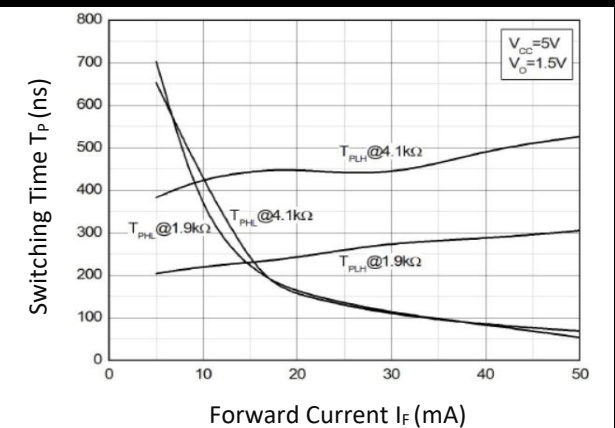



## TEST CIRCUIT:

Test Circuit of TPHL, TPLH,  $t_r$ ,  $t_f$ :

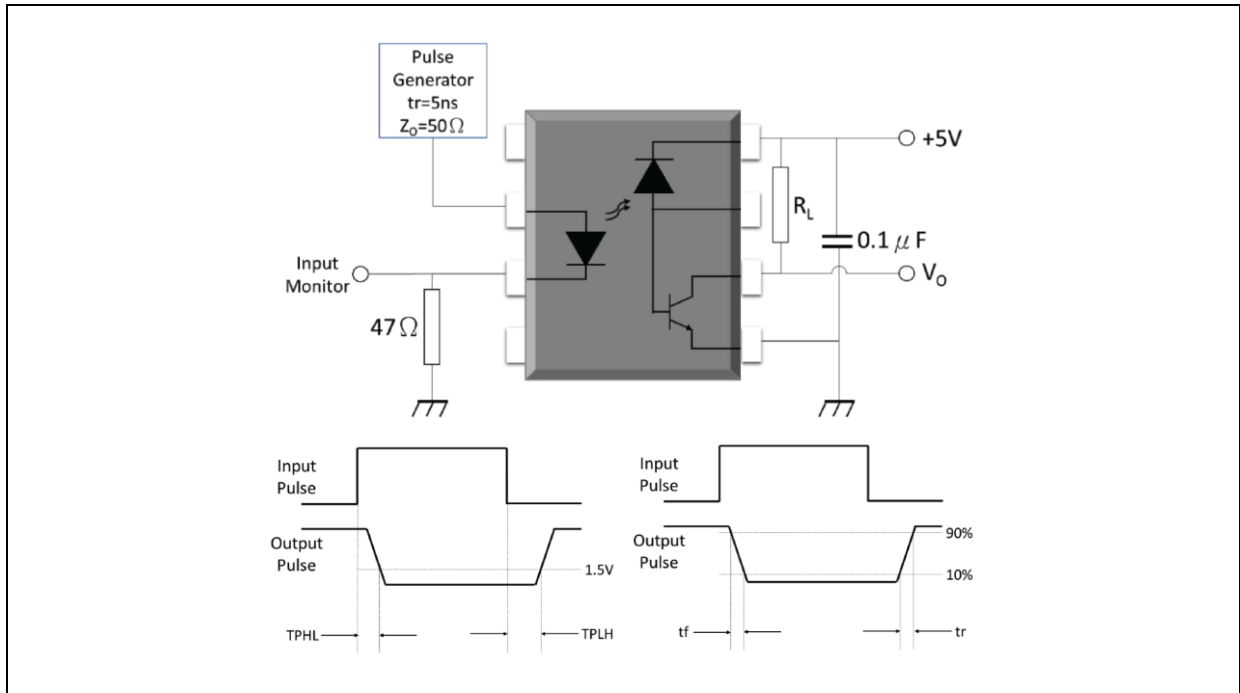

Test Circuit of Common Mode Transient Immunity:

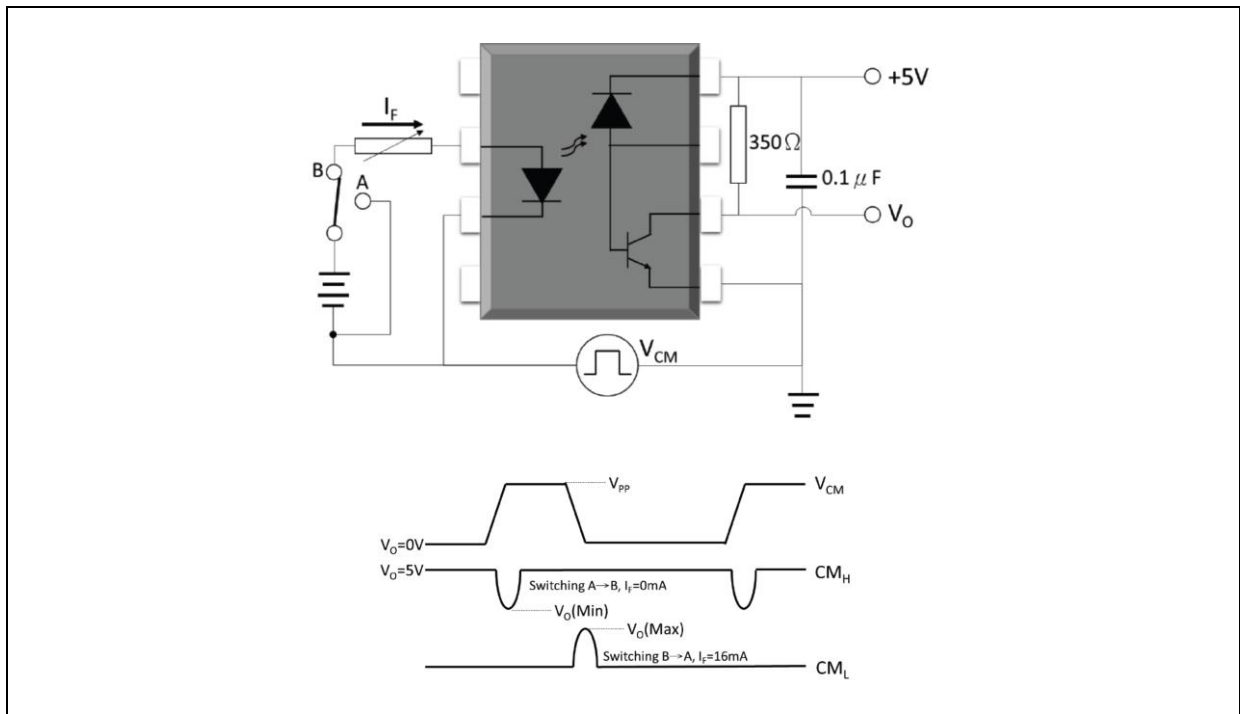

## OUTLINE DIMENSION:

Package Dimension:

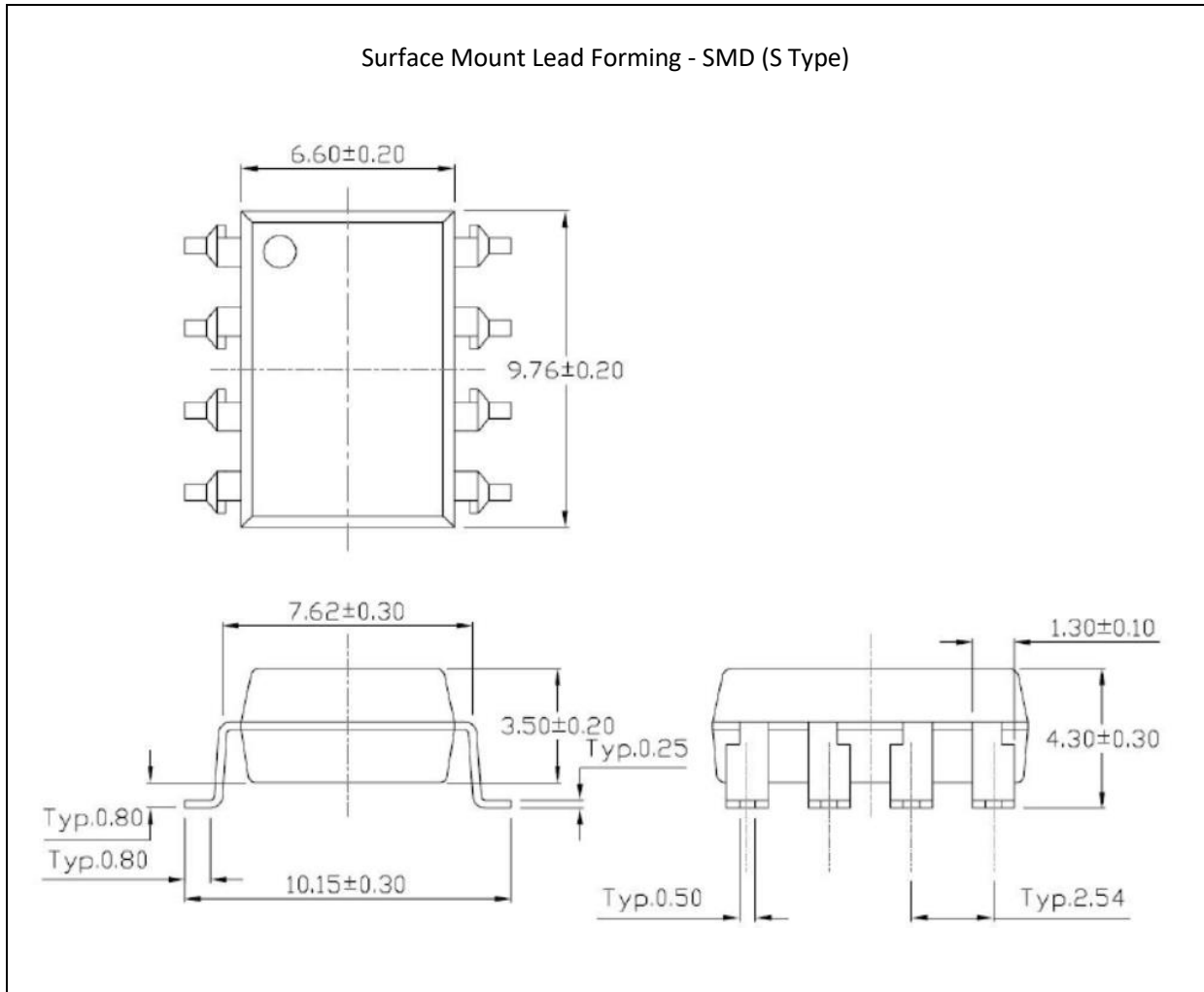

1. All dimensions are in millimetre (mm).

## Recommended Soldering Mask:

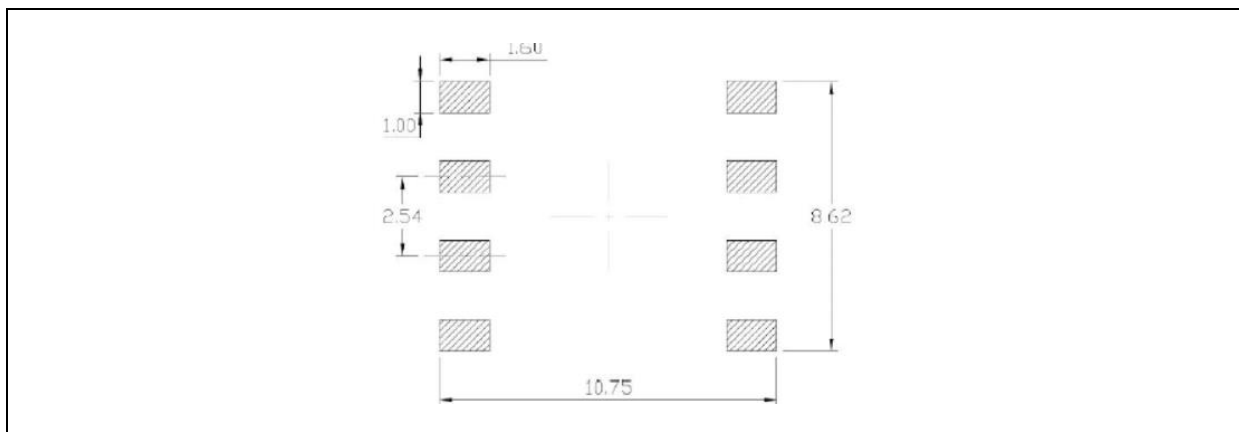

1. Dimensions are in millimetre (mm).

## PACKING SPECIFICATION:

Reel Dimension:

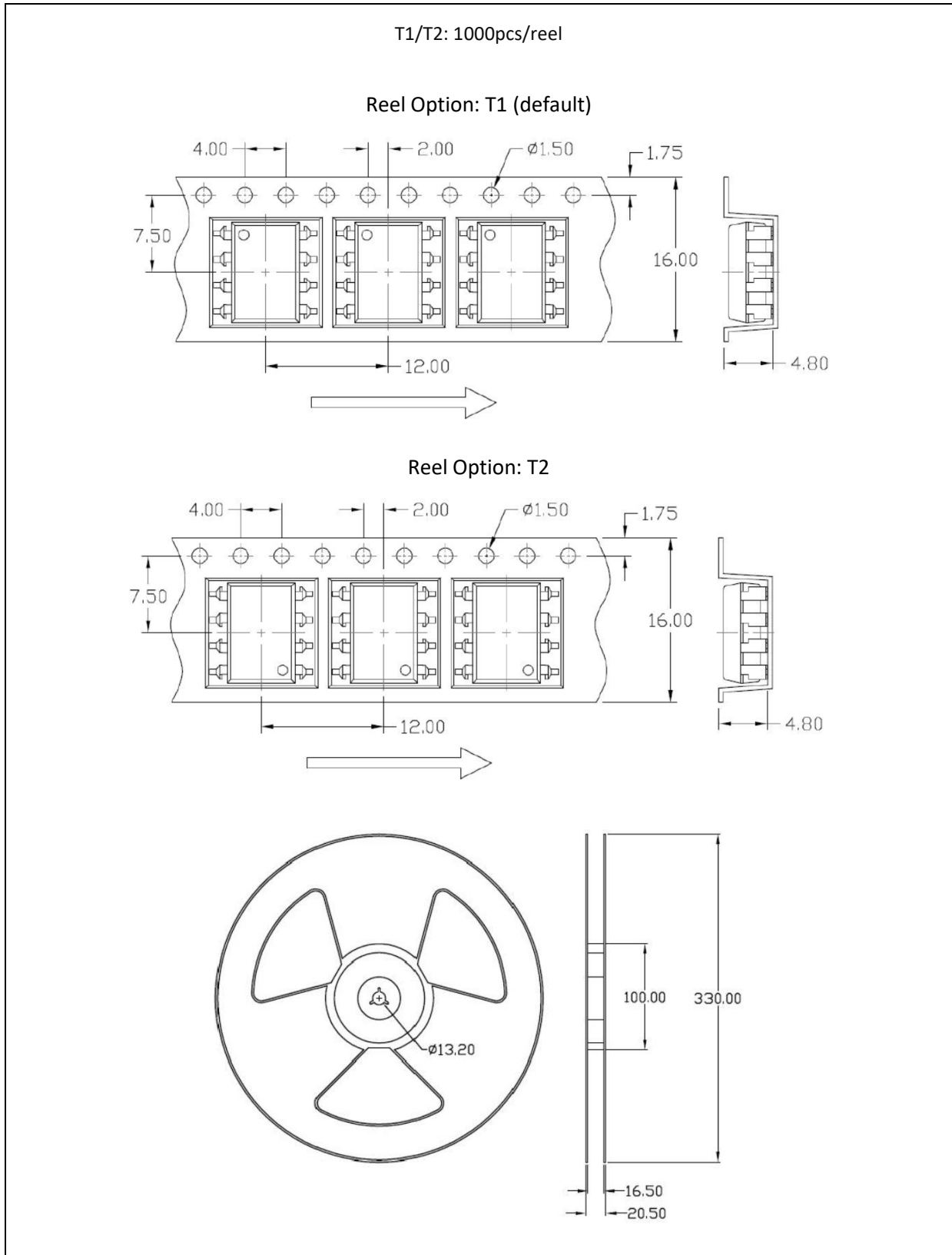

Box Dimension:

T1/T2: 3 reels (3Kpcs)/inner box, 5 inner boxes (15Kpcs)/carton

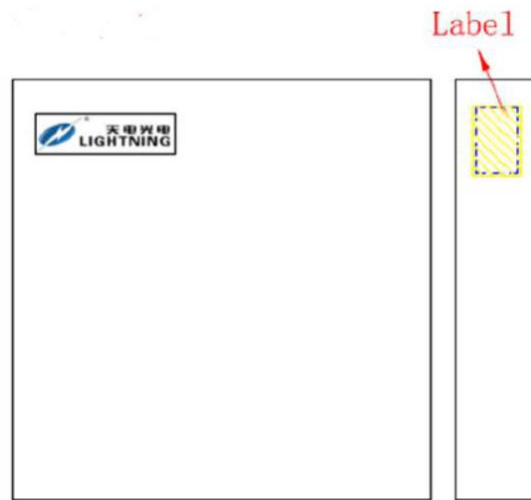

- L x W x H = 36cm x 36cm x 6.9cm

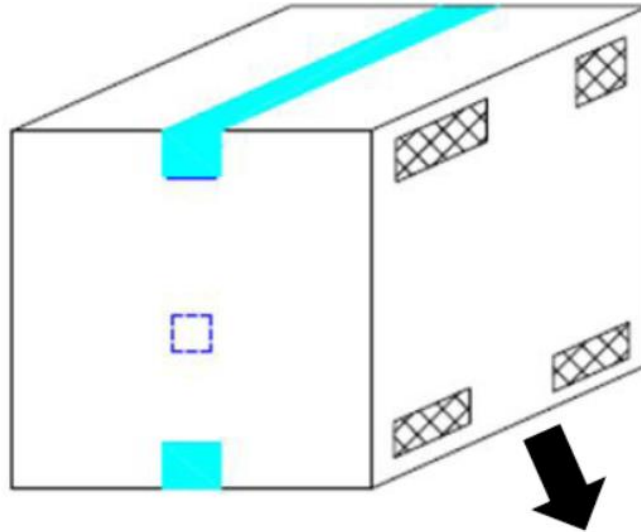

- L x W x H = 45cm x 38cm x 38cm

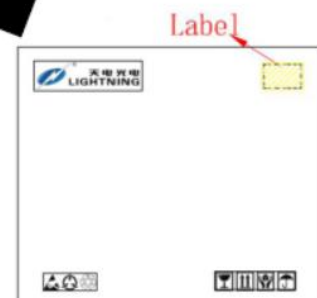

## RECOMMENDED SOLDERING PROFILE:

Reflow Information:

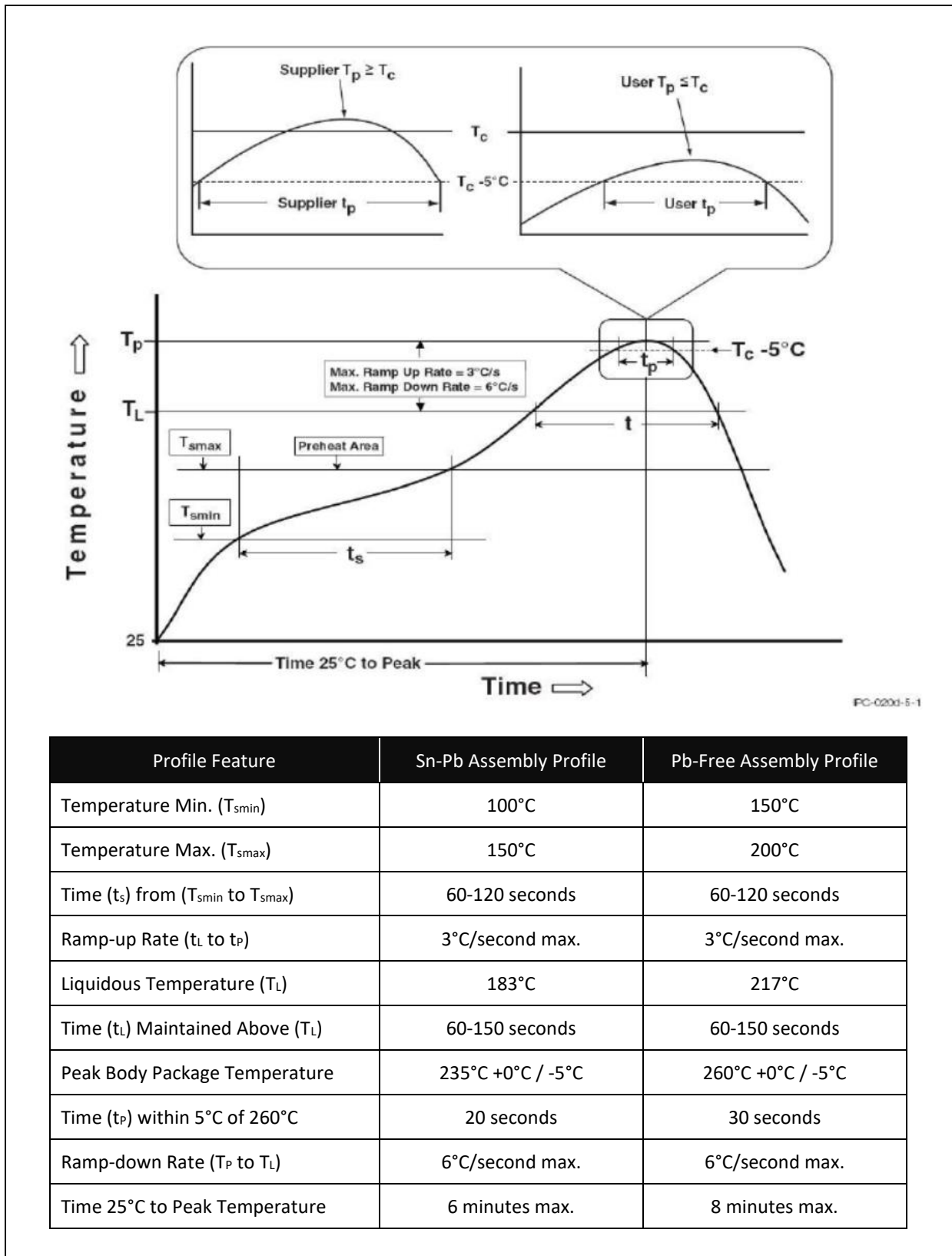

Profile Feature	Sn-Pb Assembly Profile	Pb-Free Assembly Profile
Temperature Min. ( $T_{smin}$ )	100°C	150°C
Temperature Max. ( $T_{smax}$ )	150°C	200°C
Time ( $t_s$ ) from ( $T_{smin}$ to $T_{smax}$ )	60-120 seconds	60-120 seconds
Ramp-up Rate ( $t_L$ to $t_p$ )	3°C/second max.	3°C/second max.
Liquidous Temperature ( $T_L$ )	183°C	217°C
Time ( $t_L$ ) Maintained Above ( $T_L$ )	60-150 seconds	60-150 seconds
Peak Body Package Temperature	235°C +0°C / -5°C	260°C +0°C / -5°C
Time ( $t_p$ ) within 5°C of 260°C	20 seconds	30 seconds
Ramp-down Rate ( $T_p$ to $T_L$ )	6°C/second max.	6°C/second max.
Time 25°C to Peak Temperature	6 minutes max.	8 minutes max.