



BRIGHTTEK
BRIGHTTEK (EUROPE) LIMITED

Brighten up The World With LED!



ISO/TS 16949:2009



BS EN ISO 14001:2004



QC 080000 IECQ HSPM

PRODUCT DATASHEET



- ▶ PLCC Side View w/ IC
- ▶ 5016SV IC 1.8t
- ▶ Warm White/Red/
Green/Blue

NOM67S20ICSV



Release Date: 18 September 2024 Version: A1.1



5016SV IC Integrated

5016SV IC-Integrated



FEATURES:

- **Package:** PLCC Side View Package with Integrated IC
- **R/G/B Output Current (typ.):** 12mA
- **Logical Supply Voltage:** +3.5~+7.5V
- **Luminous Intensity (typ.):** 11lm/250/700/250mcd
- **Colour:** Warm White 2700K/Red/Green/Blue
- **Materials:**
 - Die: InGaN/AlGaInP/InGaN/InGaN
 - Casting: Silicone (Yellow Diffused/Water Clear)
- **IC Feature:** Control IC and RGBW LED chip integrated 5016 package. Out R/G/B/W output gray level: 256 levels. Built-in high precision and high stability oscillator. Single-line data transmission in series, infinitely cascade. Cascaded data output after shaping to prevent data attenuation. Data transmission rate: 800Kbps. No less than 1024 level connection at 30 frames per second. Synchronous refresh of display data in the same frame
- **Soldering Methods:** Reflow soldering
- **MSL Level:** acc. to JEDEC Level 5a
- **Packing:** 12mm tape with max.800pcs/reel, ø180mm (7")

APPLICATIONS:

- Telecommunication
- Indicator
- Home Appliance
- Decoration Lighting
- Full Colour LED Strip
- Gaming Device
- Guardrail Tube
- LED Screen

CHARACTERISTICS:

Absolute Maximum Characteristics (Ta=25°C)

Parameter	Symbol	Ratings	Unit
Logical Supply Voltage	V _{DD}	+3.5~+7.5	V
Logical Input Voltage	V _I	-0.5~+5.5	V
Working Temperature	T _{OPT}	-40~+85	°C
Storage Temperature	T _{STG}	-40~+120	°C
Electrostatic Discharge (HBM)	V _{ESD}	4000	V

Electrical & Optical Characteristics

Parameter	Symbol	Values			Unit	Test Condition	
		Min.	Typ.	Max.			
Chip Internal Power Supply Voltage	V _{DD}	---	5.0	7.5	V	---	
High Level Input Voltage	V _{IH}	0.7V _{DD}	---	---	V	---	
Low Level Input Voltage	V _{IL}	---	---	0.3V _{DD}	V	---	
PWM Frequency	F _{PWM}	---	4	---	KHz	---	
Static Power Consumption	I _{DD}	---	5	---	μA	---	
Chromaticity	White	CCT	2600	---	2800	K	I _F =12mA
Dominant Wavelength	Red	λ _d	620	---	625	nm	I _F =12mA
	Green		520	---	525		
	Blue		465	---	470		
Luminous Flux	White	Φ _v	10	---	12	lm	I _F =12mA
Luminous Intensity	Red	I _v	200	---	300	mcd	I _F =12mA
	Green		600	---	800		
	Blue		200	---	300		

Switching Characteristics (Ta=25°C)

Parameter	Symbol	Values			Unit	Test Condition
		Min.	Typ.	Max.		
Data Rate	F _{DIN}	---	800	1100	KHz	---
Transmission Delay Time	T _{PLZ}	---	---	500	ns	DIN-DO

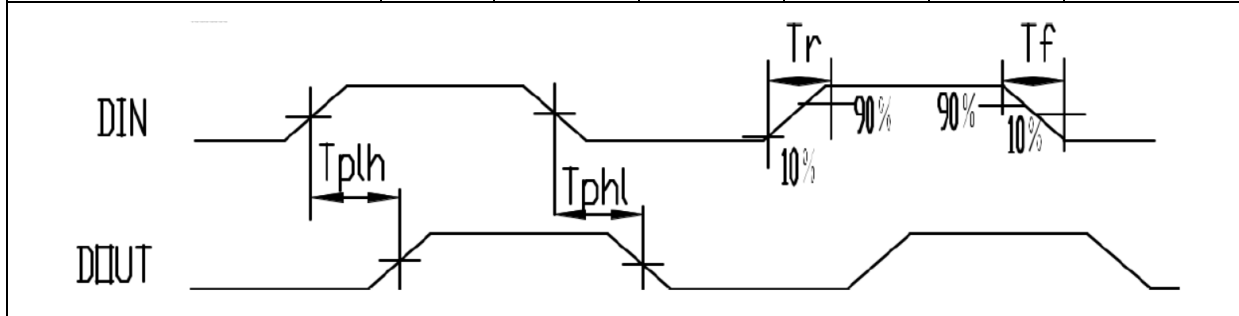

OUTLINE DIMENSION:

Package Dimension:

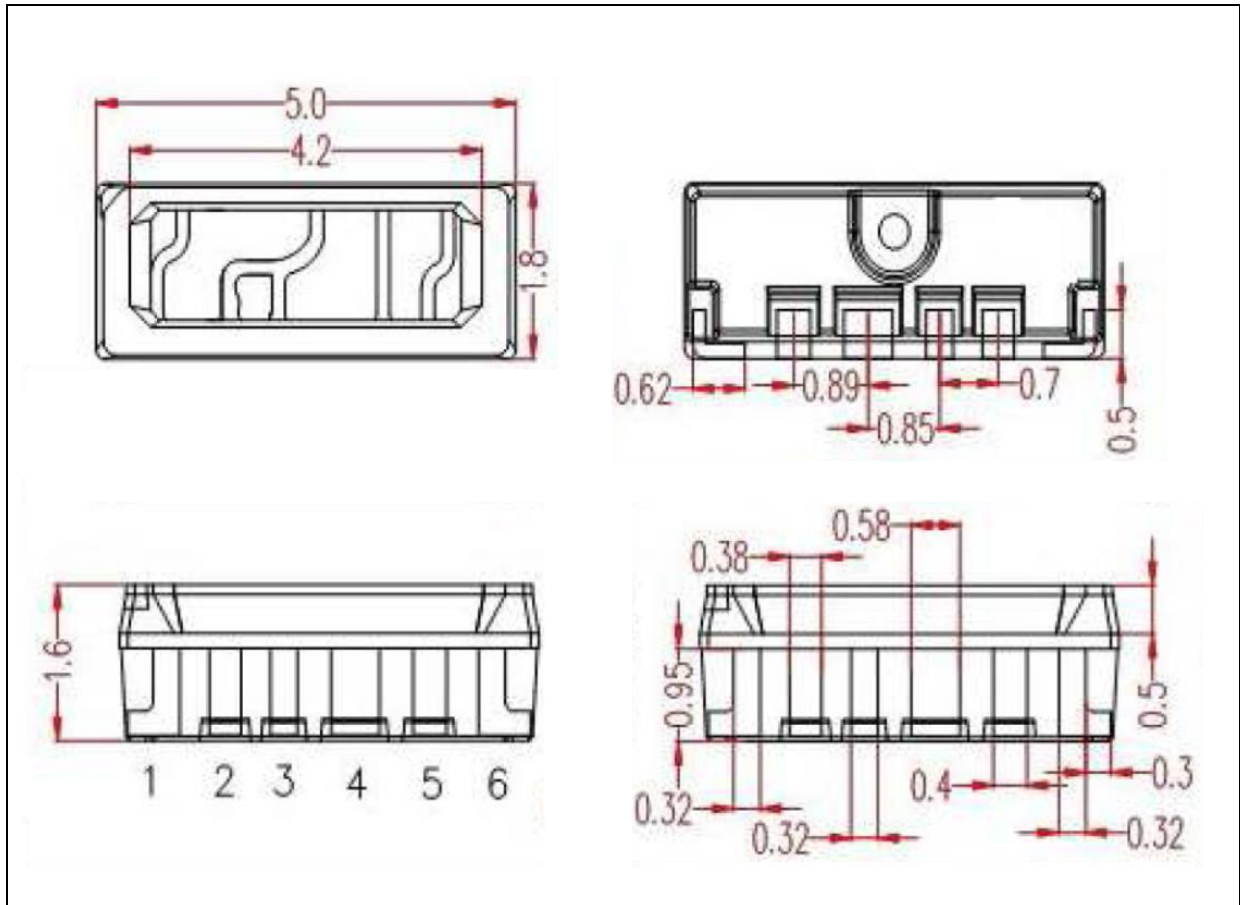

1. All dimensions are in millimetre (mm).
2. Tolerance $\pm 0.1\text{mm}$, unless otherwise noted.

Recommended Soldering Pad Dimension:

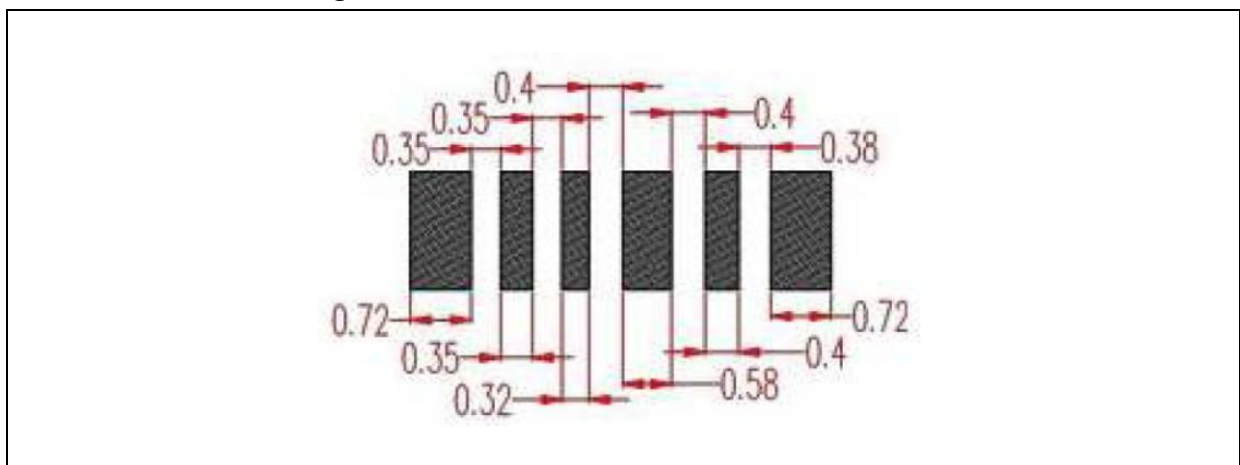

1. Dimensions are in millimetre (mm).
2. Tolerance $\pm 0.1\text{mm}$ with angle tolerance $\pm 0.5^\circ$.

PIN CONFIGURATION:



No.	Symbol	Function Description
1	VDD	White light supply pin
2	NC	Connect the white light cathode to the IC white light output port
3	DOUT	Control data signal output
4	VDD	Power supply pin
5	DIN	Control data signal input
6	GND	Signal and power grounding

FUNCTION DESCRIPTION:

1. Data Transmission Form:

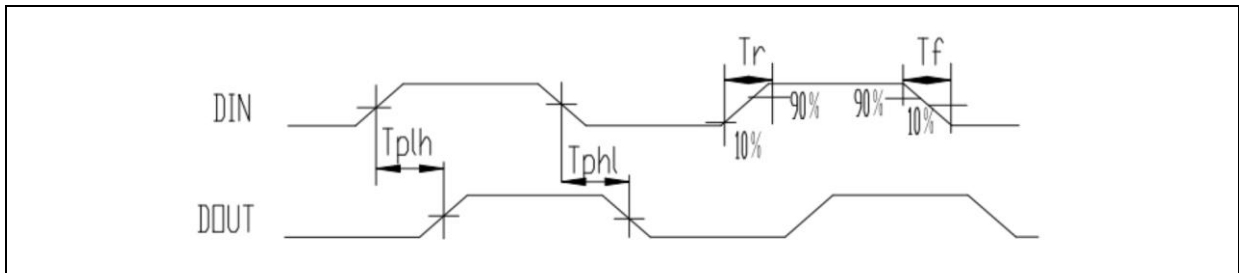

2. Data Transmission Time:

Symbol	Description	Min	Typ	Max	Unit
T0H	0 code, high level time	0.25	0.3	0.35	us
T0L	0 code, low level time	0.85	0.9	0.95	us
T1H	1 code, high level time	0.85	0.9	0.95	us
T1L	1 code, low level time	0.25	0.3	0.35	us
Trst	Rest code, low level time	80	-	-	us

3. Temporal Wave Form Figure Type of Input:

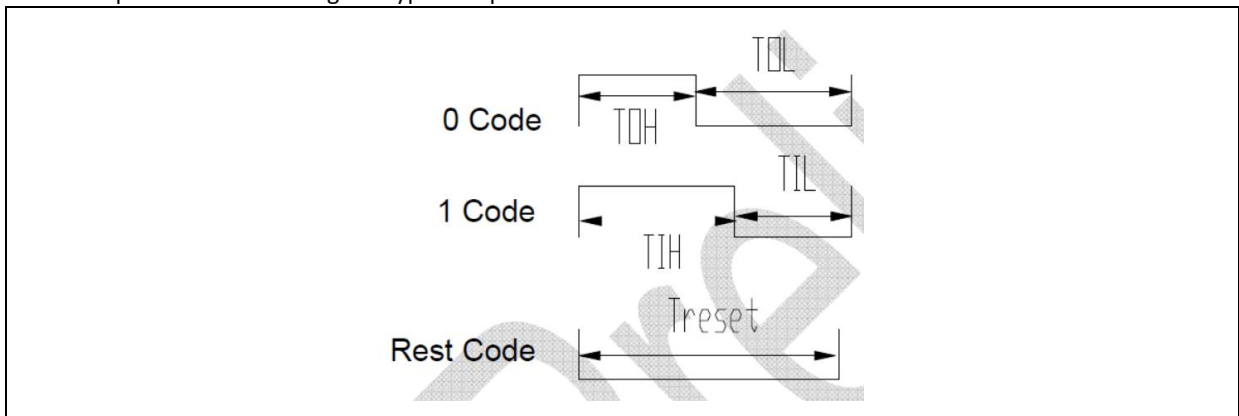

4. Connection Mode:

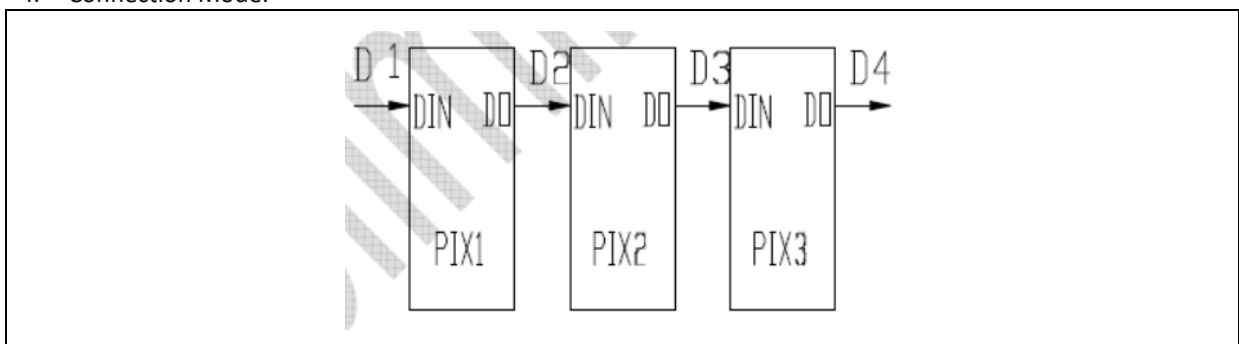

5. Mode of Data Transmission:

32bit data structure:



Note: High start, send data in GRBW order (G7→G6.....W0)

20bit gain data structure:



Note: High start, send data in GRBW order (GG4→GG3.....GW0)

6. Gain Table:

RGBW Gain control bit	Constant output current(mA)	RGBW Gain control bit	Constant output current(mA)
00000	2.4	10000	21.6
00001	3.6	10001	22.8
00010	4.8	10010	24.0
00011	6.0	10011	25.2
00100	7.2	10100	26.4
00101	8.4	10101	27.6
00110	9.6	10110	28.8
00111	10.8	10111	30.0
01000	12.0	11000	31.2
01001	13.2	11001	32.4
01010	14.4	11010	33.6
01011	15.6	11011	34.8
01100	16.8	11100	36.0
01101	18.0	11101	37.2
01110	19.2	11110	38.4
01111	20.4	11111	39.6

7. Gain Table:

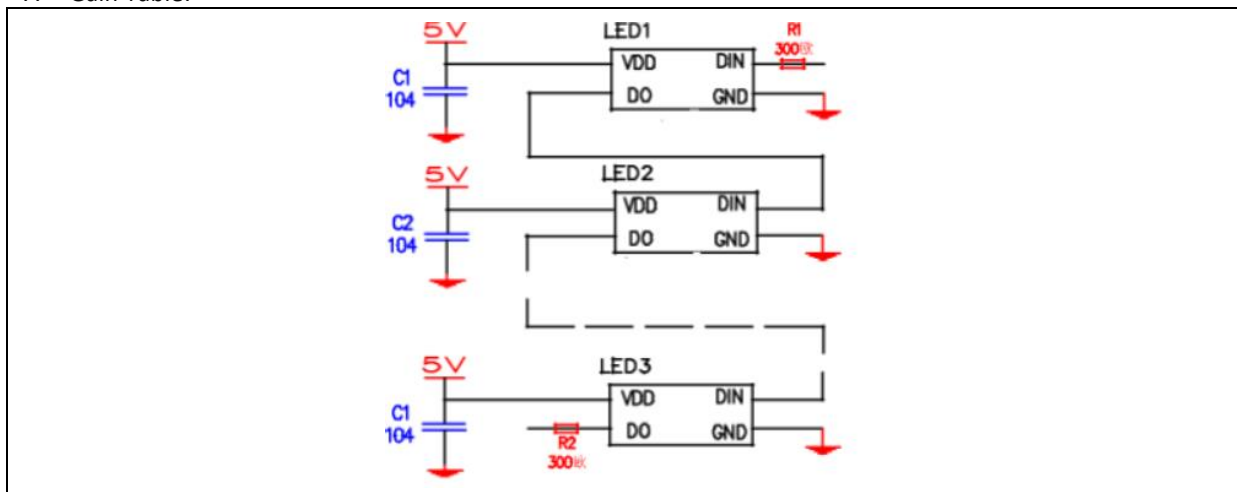

RECOMMENDED SOLDERING PROFILE:

Lead-free Solder IR Reflow:

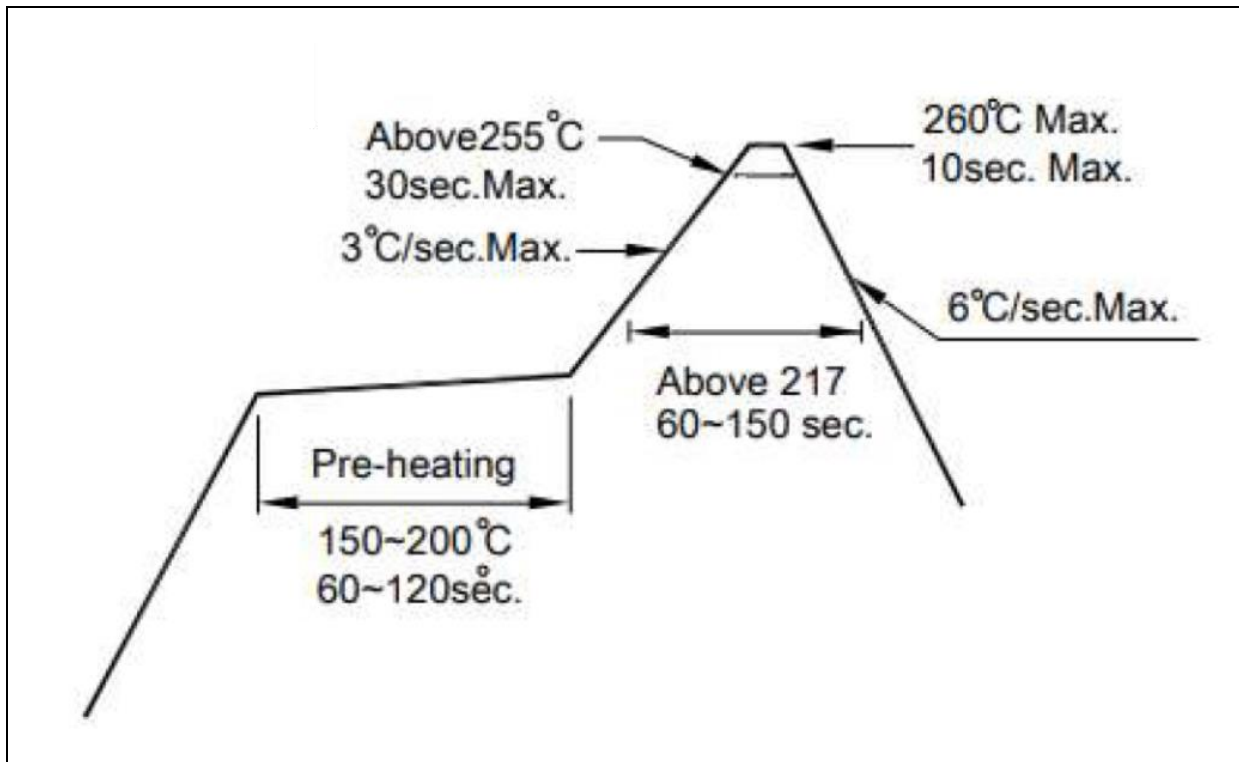

Note:

1. The maximum soldering temperature should be limited to 240°C. The maximum soldering temperature should be limited to 260°C.
2. Maxima reflow soldering: 2 times.
3. Before, during, and after soldering, should not apply stress on the components and PCB board.

PACKING SPECIFICATION:

Reel Dimension:

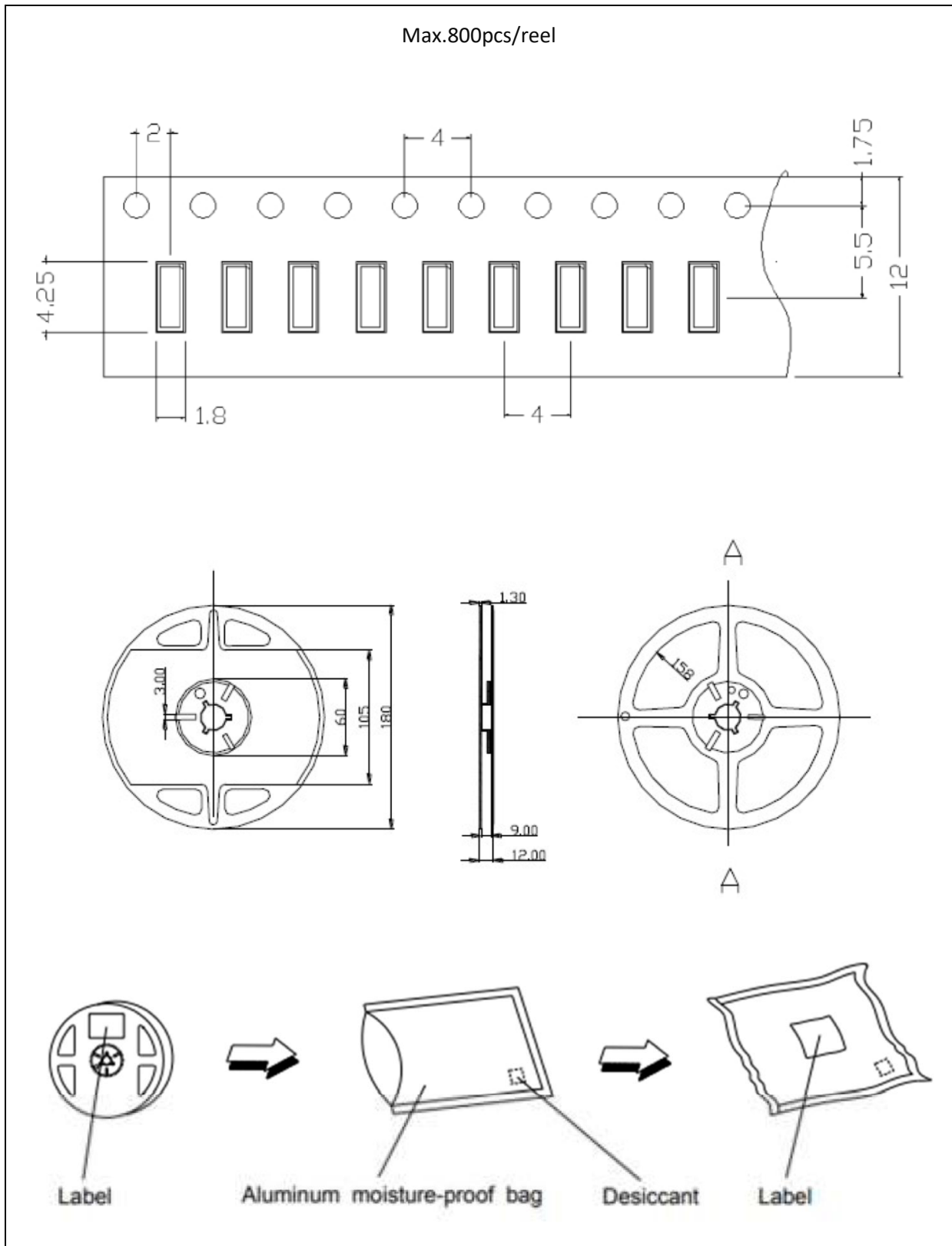

PRECAUTIONS OF USE:

Storage:

It is recommended to store the products in the following conditions:

- Humidity: 60% R.H. Max.
- Temperature: 5°C~30°C (41°F ~86°F).

Shelf life in sealed bag: 12 months at 5°C~30°C and <60% R.H.

Once the package is opened, the products should be used within 24 hours. Otherwise, they should be kept in a damp-proof box with desiccating agent stored at R.H.<10% and apply baking before use.

Over-Current Proof:

Must apply resistors for protection otherwise slight voltage shift will cause big current change and burn-out will happen.

Baking:

It is recommended to bake the LED before soldering if the pack has been unsealed for longer than 24hrs. The suggested baking conditions are as followings:

- 60±5°C x 48hrs and <5%RH, taped / reel package.

It's normal to see slight color fading of carrier (light yellow) after baking in process.

Cleaning:

Use alcohol-based cleaning solvents such as isopropyl alcohol to clean the LED carrier / package. Avoid putting any stress force directly on to the LED lens.

ESD (Electrostatic Discharge):

Static Electricity or power surge will damage the LED. Use of a conductive wrist band or anti-electrosatic glove is recommended when handling the LED all time. All devices, equipment, machinery, work tables, and storage racks must be properly grounded.

REVISION RECORD:

Version	Date	Summary of Revision
A1.0	02/09/2022	Datasheet set-up.
A1.1	17/09/2024	Update MSL level.