



**BRIGHTTEK**  
**BRIGHTTEK (EUROPE) LIMITED**

*Brighten Up The World With LED!*



ISO/TS 16949:2009



BS EN ISO 14001:2004



QC 080000 IECQ HSPM

## PRODUCT DATASHEET



- ▶ SMD with Touch IC
- ▶ 5050 IC 1.0t
- ▶ Red/Green/Blue + Touch Sensor

NOM61S45ICT



Release Date: 18 September 2022 Version: A1.1

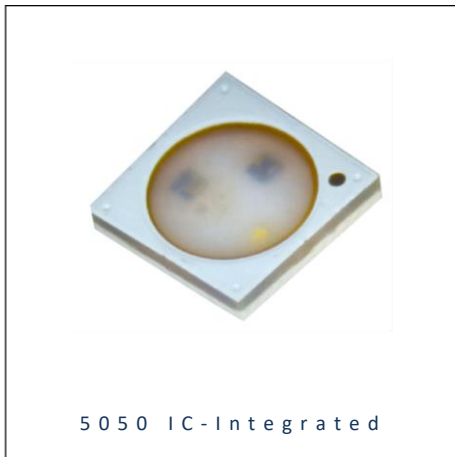

### 5050 IC-Integrated

**RoHS**  
Compliant



#### FEATURES:

- **Package:** Top View Package with Touch Detection and RGB Integrated IC Control
- **Forward Current:** 12/12/12mA\*
- **Forward Voltage (typ.):** +3.3~+5.5V
- **Luminous Intensity (typ.):** 320/700/150mcd
- **Colour:** Red/Green/Blue
- **Wavelength:** 622/525/468nm
- **Viewing angle:** 120°
- **Materials:**
  - Resin: Silicone (White Diffused)
  - L/F Finish: Ag Plated
- **Operating Temperature:** -25~+85°C
- **Storage Temperature:** -30~+100°C
- **Pixel:** 256 step gray-scale output to allow 16,777,216 colour display
- **Touch Sensor Type:** Capacitive Sensing
- **Soldering methods:** IR Reflow soldering
- **Preconditioning:** acc. to JEDEC Level 3
- **Packing:** 12mm tape with max.1000pcs/reel, ø180mm (7")

\* in order of Red/Green/Blue

#### APPLICATIONS:

- Telecommunication
- Indicator
- Home Appliance
- Decoration Lighting
- Full Colour LED Strip
- Gaming Device
- Guardrail Tube
- Button Keys

**CHARACTERISTICS:**

## Absolute Maximum Characteristics (Ta=25°C)

Parameter	Symbol	Ratings	Unit
Supply Voltage	V <sub>DD</sub>	3.3 ~ 5.5	V
Operating Temperature	T <sub>OPR</sub>	-25~+85	°C
Storage Temperature	T <sub>STG</sub>	-30~+100	°C

 Electrical & Optical Characteristics (Ta=25°C, V<sub>DD</sub>=5V)

Parameter	Symbol	Values			Unit	Test Condition	
		Min.	Typ.	Max.			
Touch Sensing IC	Supply Voltage	V <sub>DD</sub>	3.3	5.0	5.5	V	---
	Standby Current	I <sub>OPL</sub>	---	10.5	---	μA	V <sub>DD</sub> =5V No Load
	High Level Input Voltage	V <sub>IH</sub>	2/3	---	---	V <sub>DD</sub>	V <sub>DD</sub>
	Low Level Input Voltage	V <sub>IL</sub>	---	---	1/3	V <sub>DD</sub>	V <sub>DD</sub>
	Output Response Time	T <sub>R</sub>	---	48	---	ms	V <sub>DD</sub> =5V
Addressable RGB IC	Supply Voltage	V <sub>DD</sub>	3.3	5.0	5.5	V	---
	Each R/G/B Current	I <sub>OL</sub>	---	12	---	mA	V <sub>DD</sub> =5V
	Input High Voltage	V <sub>IH</sub>	2.7	---	V <sub>DD</sub>	V	---
	Input Low Voltage	V <sub>IL</sub>	0	---	1	V	---
Luminous Intensity	R	I <sub>v</sub>	---	320	---	mcd	V <sub>DD</sub> =5V
	G		---	700	---		
	B		---	150	---		
Dominant Wavelength	R	λ <sub>D</sub>	---	622	---	nm	V <sub>DD</sub> =5V
	G		---	525	---		
	B		---	468	---		
Viewing Angle	2θ <sub>1/2</sub>		---	120	---	deg	V <sub>DD</sub> =5V

## OUTLINE DIMENSION:

Package Dimension:

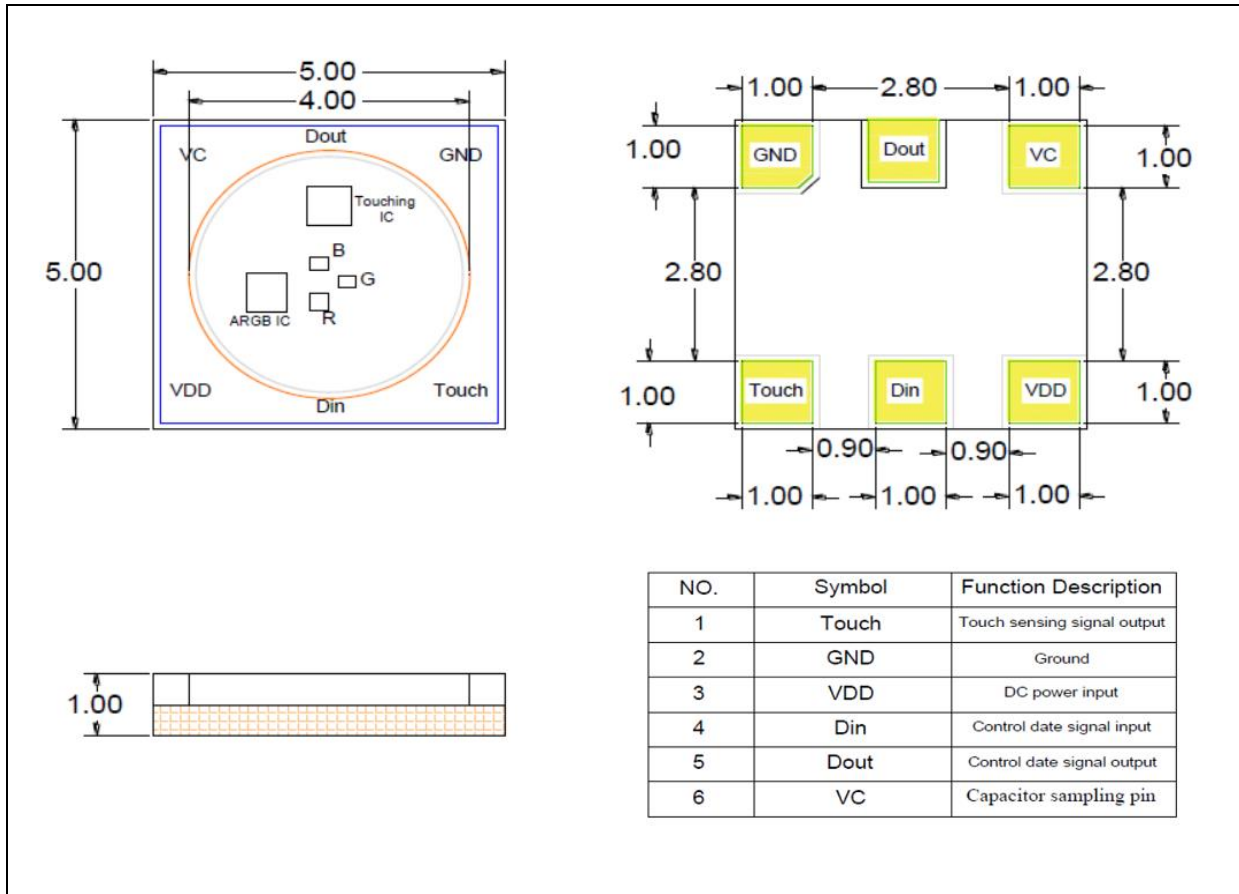

1. All dimensions are in millimetre (mm).
2. Tolerance  $\pm 0.2\text{mm}$ , unless otherwise noted.

Recommended Soldering Pad Dimension:

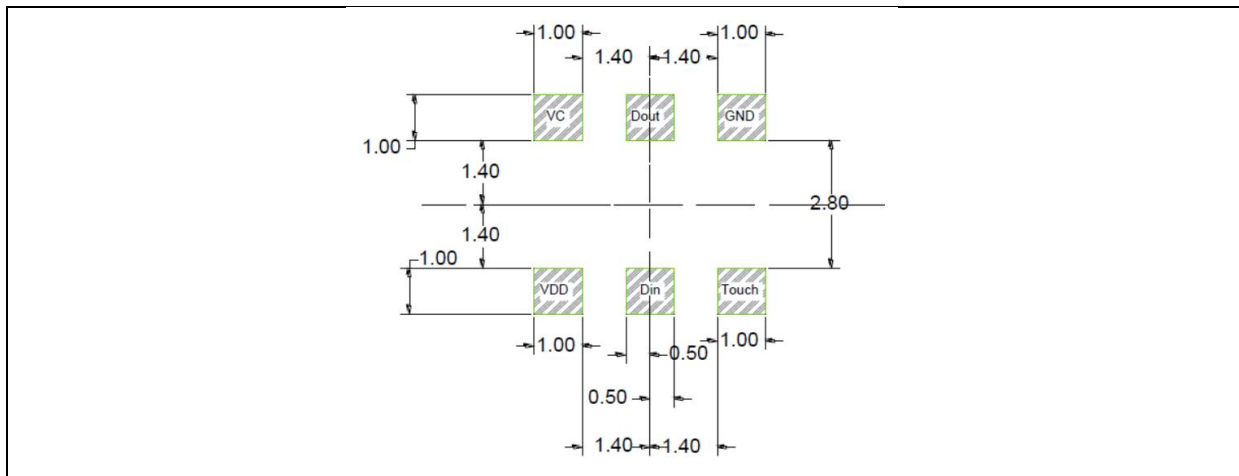

1. Dimensions are in millimetre (mm).
2. Tolerance  $\pm 0.1\text{mm}$  with angle tolerance  $\pm 0.5^\circ$ .

## Function Description:

### 1. Touch Sensing Function:

#### Features:

- At low power mode typical 10.5uA@5V.
- Sensitivity can adjust by the capacitance outside.
- Auto calibration for life.
- Stable touching detection with isolation object cover the component.

#### Time Chart:

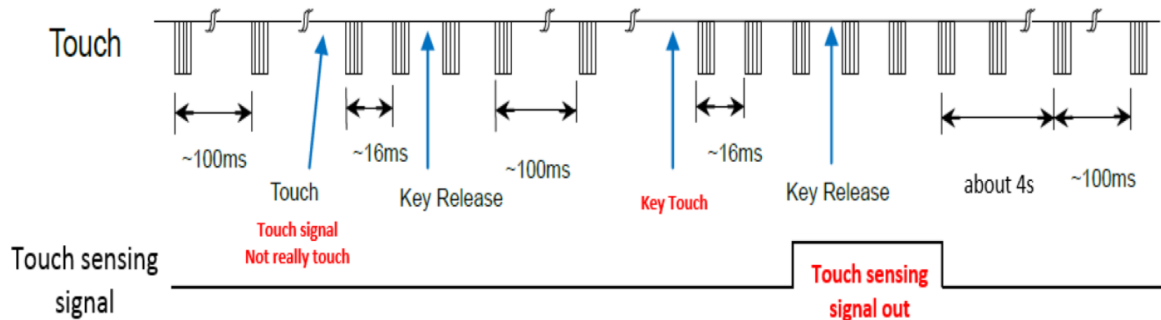

### 2. Addressable RGB Function:

#### Features:

- Support control circuit to be integrated with RGB chips into a single package.
- Support signal reshaping to pass control waveforms to next adjacent driver.
- 256-step gray-scale output to allow 16,777,216 colour display.
- Constant current PWM control.

#### Timing Wave Form:

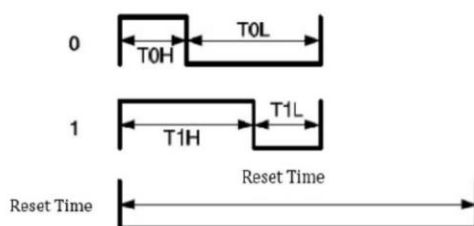

Item	Description	min	Typical	Allowance	unit
T0H	0 code, High-level time		0.3	±0.15	us
T0L	0 code, Low-level time		0.9	±0.15	us
T1H	1 code, High-level time		0.9	±0.15	us
T1L	1 code, Low-level time		0.3	±0.15	us
Trst	Reset code, Low-level time	250			us

Single data in 24 bits for RGB:

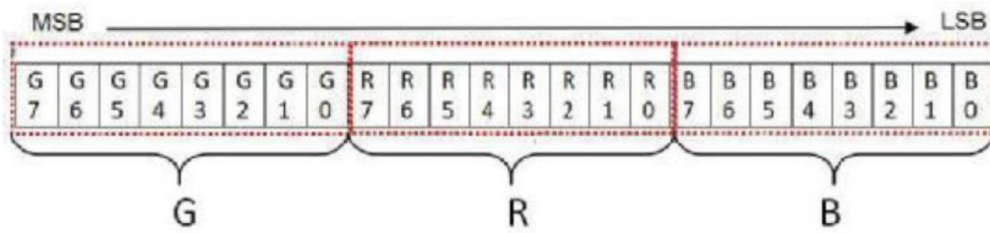

### 3. Advance function mode:

This product has an Advance Function Mode that supports the MCU to start with a specific command setting.

Advance Function Mode including the following functions:

1. Feedback the cascaded number of LEDs and maximum sink current of R/G/B channel.
2. Current Gain control: 32 level (5bits) to adjust maximum sink current of R/G/B channel.
3. Programmable PWM refresh rate (1.25kHz/2.5kHz/5kHz/10kHz).

### 4. Application Circuit:

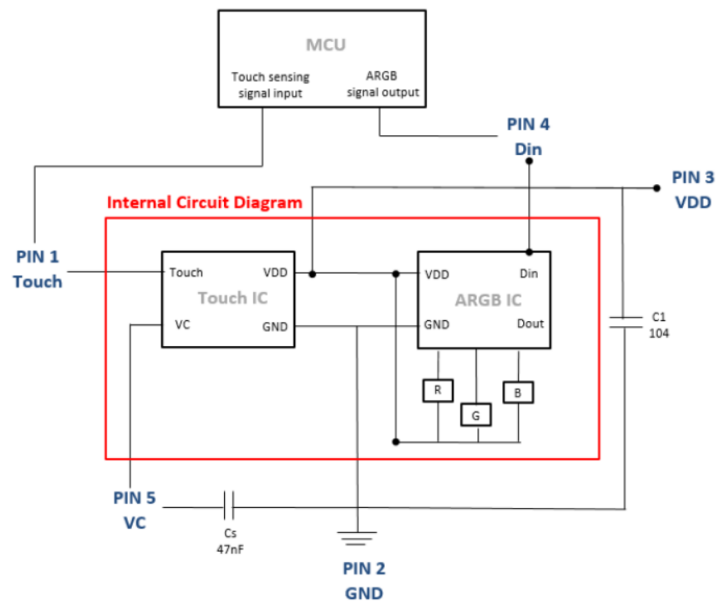

Application Note:

1. Initial Pin 1 (Touch) output is 0 (Low level) as power on. When touching sensor detect a touch, Pin 1 (Touch) switch to 1 (High level). When the touching sensing is removed. It will switch Pin 1 (Touch) from 1 (High level) to 0 (Low level).
2. When Pin5 (VC) is Adding the Cs (47nF) to VSS, the sensitivity is most sensitive. When reduce the values of Cs. It will reduce sensitivity in the useful range. ( $1\text{nF} \leq C_s \leq 47\text{nF}$ ).
3. The material of panel covering on the PCB cannot include the metal or the electric element. The paints on the surfaces are the same. The cover's thickness design rule is under 2mm.
4. The power supply must be stable. If the supply voltage drift or shift quickly, maybe causing sensitivity anomalies or false detections.
5. The sensitivity adjustment capacitors (Cs) must use smaller temperature coefficient and more stable capacitors. Such as X7R, NPO for example. So for touch application, recommend to use NPO capacitor, for reducing that the temperature varies to affect sensitivity.

## RECOMMENDED SOLDERING PROFILE:

---

Lead-free Solder IR Reflow:

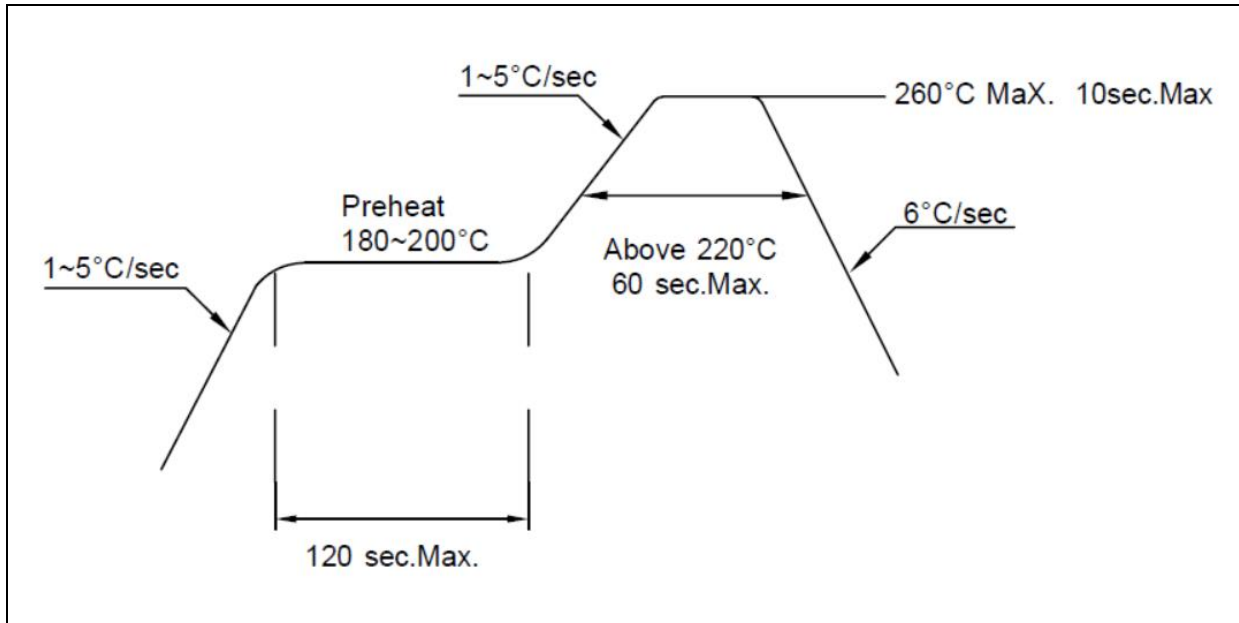

Note:

1. We recommend the reflow temperature 240°C ( $\pm 5^\circ\text{C}$ ). The maximum soldering temperature should be limited to 260°C.
2. Maxima reflow soldering: 2 times.
3. Before, during, and after soldering, should not apply stress on the components and PCB board.

**PACKING SPECIFICATION:**

Reel Dimension:

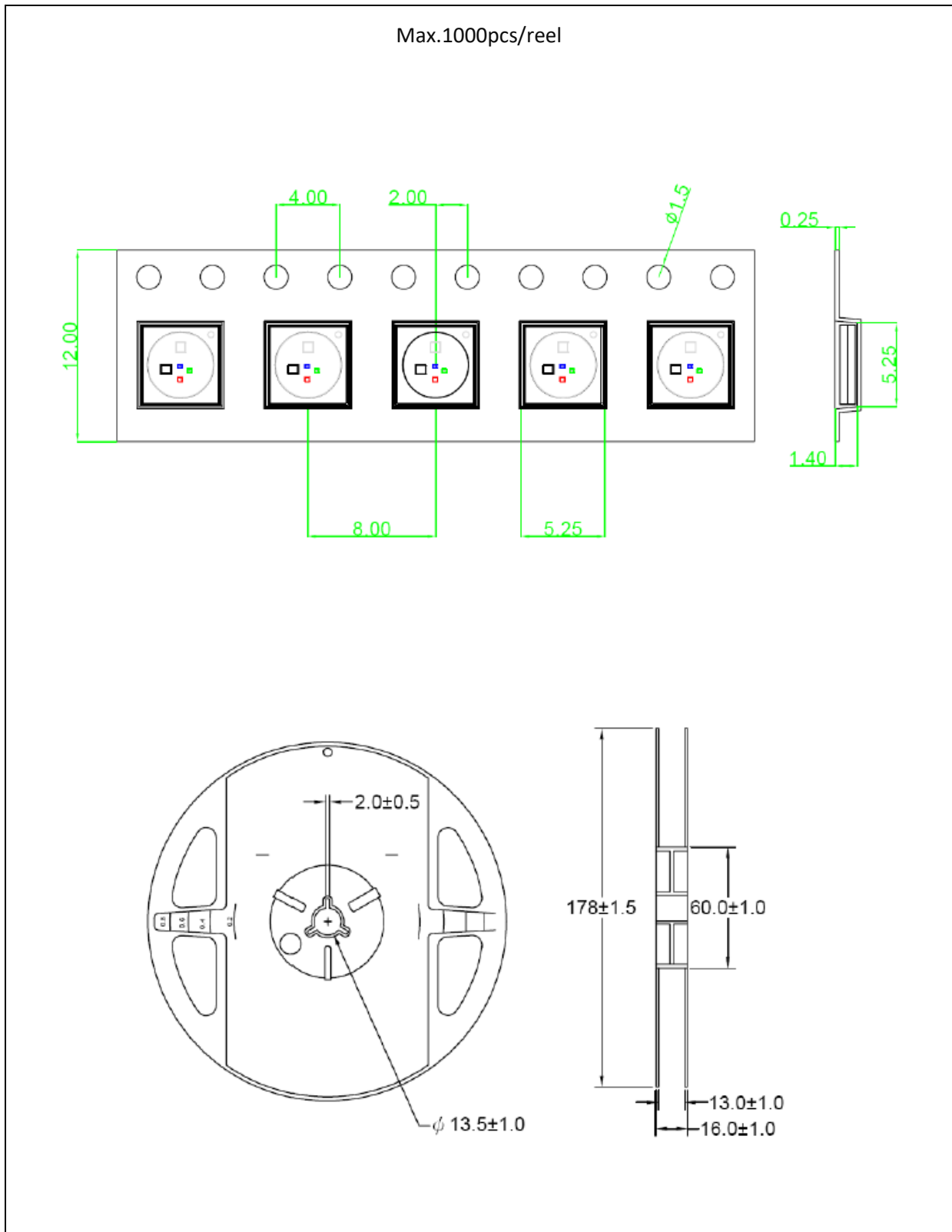

## PRECAUTIONS OF USE:

---

### Storage:

It is recommended to store the products in the following conditions:

- Humidity: 60% R.H. Max.
- Temperature: 5°C~30°C (41°F ~86°F).

Shelf life in sealed bag: 12 months at 5°C~30°C and <60% R.H.

Once the package is opened, the products should be used within 72 hours. Otherwise, they should be kept in a damp-proof box with desiccating agent stored at R.H.<10% and apply baking before use.

### Over-Current Proof:

Must apply resistors for protection otherwise slight voltage shift will cause big current change and burn-out will happen.

### Baking:

It is recommended to bake the LED before soldering if the pack has been unsealed for longer than 24hrs. The suggested baking conditions are as followings:

- 60±5°C x 24hrs and <5%RH, taped / reel package.

It's normal to see slight color fading of carrier (light yellow) after baking in process.

### Recommended Route:

Parallel connected multi-strip control.

### Cleaning:

Use alcohol-based cleaning solvents such as isopropyl alcohol to clean the LED carrier / package. Avoid putting any stress force directly on to the LED lens.

### ESD (Electrostatic Discharge):

Static Electricity or power surge will damage the LED. Use of a conductive wrist band or anti-electrostatic glove is recommended when handling the LED all time. All devices, equipment, machinery, work tables, and storage racks must be properly grounded.



**REVISION RECORD:**

---

Version	Date	Summary of Revision
A1.0	05/08/2021	Datasheet set-up.
A.1.1	18/09/2022	Add packing drawing.