



**BRIGHTTEK**  
**BRIGHTTEK (EUROPE) LIMITED**

*Brighten Up The World With LED!*



ISO/TS 16949:2009



BS EN ISO 14001:2004



QC 080000 IECQ HSPM

## PRODUCT DATASHEET



- ▶ EMC SMD Top View
- ▶ 3838 2.21t Series
- ▶ Infrared (IR) 940nm

**NOF66S91BF**



Release Date: 04 September 2024 Version: A1.0



### 3838 2.21t Series



#### FEATURES:

- **Package:** Black Ceramic Single Junction SMT Package
- **Forward Current:** 1A
- **Pulse Forward Current (max.):** 3A
- **Forward Voltage (typ.):** 1.6V
- **Radiant Power (typ.):** 800mW@1A
- **Radiant Intensity (typ.):** 430mW/sr@1A
- **Colour:** Infrared (IR)
- **Peak Wavelength (typ.):** 940nm
- **Viewing angle:** 90°
- **Operating Temperature:** -40~+105°C
- **Storage Temperature:** -40~+105°C
- **Grouping Parameters:**
  - Forward Voltage
  - Radiant Power
  - Peak Wavelength
- **Soldering Methods:** Reflow Soldering
- **MSL Level:** MSL2 according to J-STD020
- **Corrosion Robustness Class:** 3B
- **Packing:** 12mm tape with max.800/reel, ø178mm (7")

#### APPLICATIONS:

- Automotive
- Security Camera
- Motion Detection
- Night Viewer
- Surveillance
- Data Communication

## CHARACTERISTICS:

---

### Absolute Maximum Characteristics ( $T_a=25^{\circ}\text{C}$ )

Parameter	Symbol	Ratings	Unit
DC Forward Current	$I_F$	1000	mA
Pulse Forward Current	$I_{PF}$	3	A
Power Consumption	$P_{tot}$	2	W
Reverse Voltage	$V_R$	5	V
Reverse Current @5V	$I_R$	10	$\mu\text{A}$
Junction Temperature	$T_j$	125	$^{\circ}\text{C}$
Thermal Resistance Junction to Solder Point	$R_{th}$	typ. 4.5; max. 9	K/W
Electrostatic Discharge (HBM: MIL-STD-883 C 2)	ESD	2	kV
Operating Temperature	$T_{OPR}$	-40~+105	$^{\circ}\text{C}$
Storage Temperature	$T_{STG}$	-40~+105	$^{\circ}\text{C}$
Soldering Temperature	$T_{SOL}$	260	$^{\circ}\text{C}$

Electrical & Optical Characteristics ( $T_a=25^{\circ}\text{C}$ ,  $I_f=1\text{A}$ ,  $t_p=10\text{ms}$ )

Parameter	Symbol	Values			Unit	Test Condition
		Min.	Typ.	Max.		
Forward Voltage	$V_F$	1.4	1.6	2.0	V	$I_f=1\text{A}$ $t_p=100\mu\text{s}$
Radiant Power	$\Phi_e$	700	800	1000	mW	$I_f=1\text{A}$ $t_p=100\mu\text{s}$
Radiant Intensity	$I_e$	330	430	530	mW/sr	$I_f=1\text{A}$ $t_p=100\mu\text{s}$
Peak Wavelength	$\lambda_p$	---	940	---	nm	$I_f=1\text{A}$
Spectral Bandwidth	$\Delta\lambda$	---	40	---	nm	$I_f=1\text{A}$
Viewing Angle	$2\theta_{1/2}$	---	90	---	deg	$I_f=1\text{A}$

1. Radiant Power ( $P_o$ )  $\pm 10\%$ , Forward Voltage ( $V_f$ )  $\pm 0.1\text{V}$ , Viewing angle( $2\theta_{1/2}$ )  $\pm 10^{\circ}$

## OUTLINE DIMENSION:

Package Dimension:

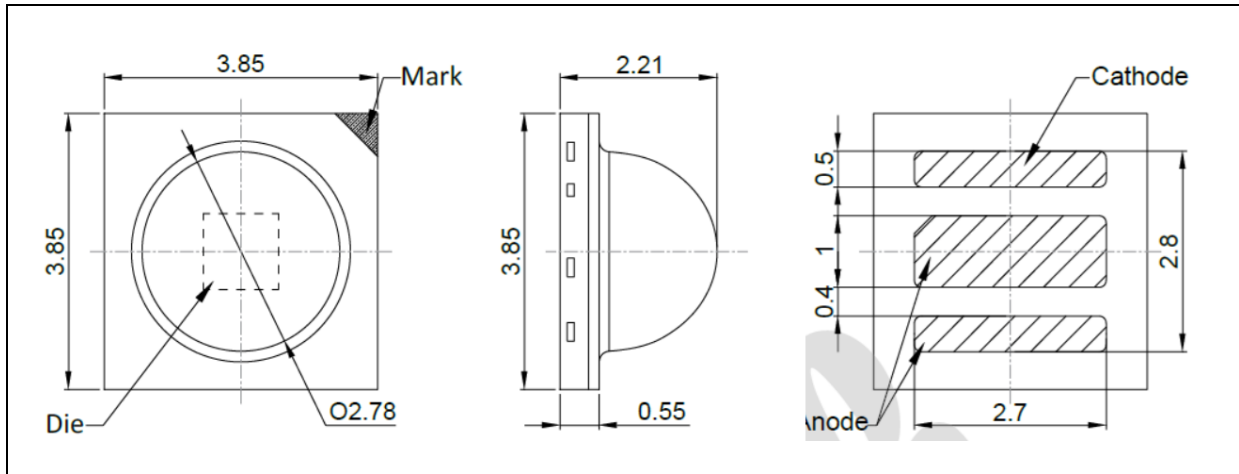

1. All dimensions are in millimetre (mm).
2. Tolerance  $\pm 0.13\text{mm}$ , unless otherwise noted.

Recommended Soldering Pad Dimension:

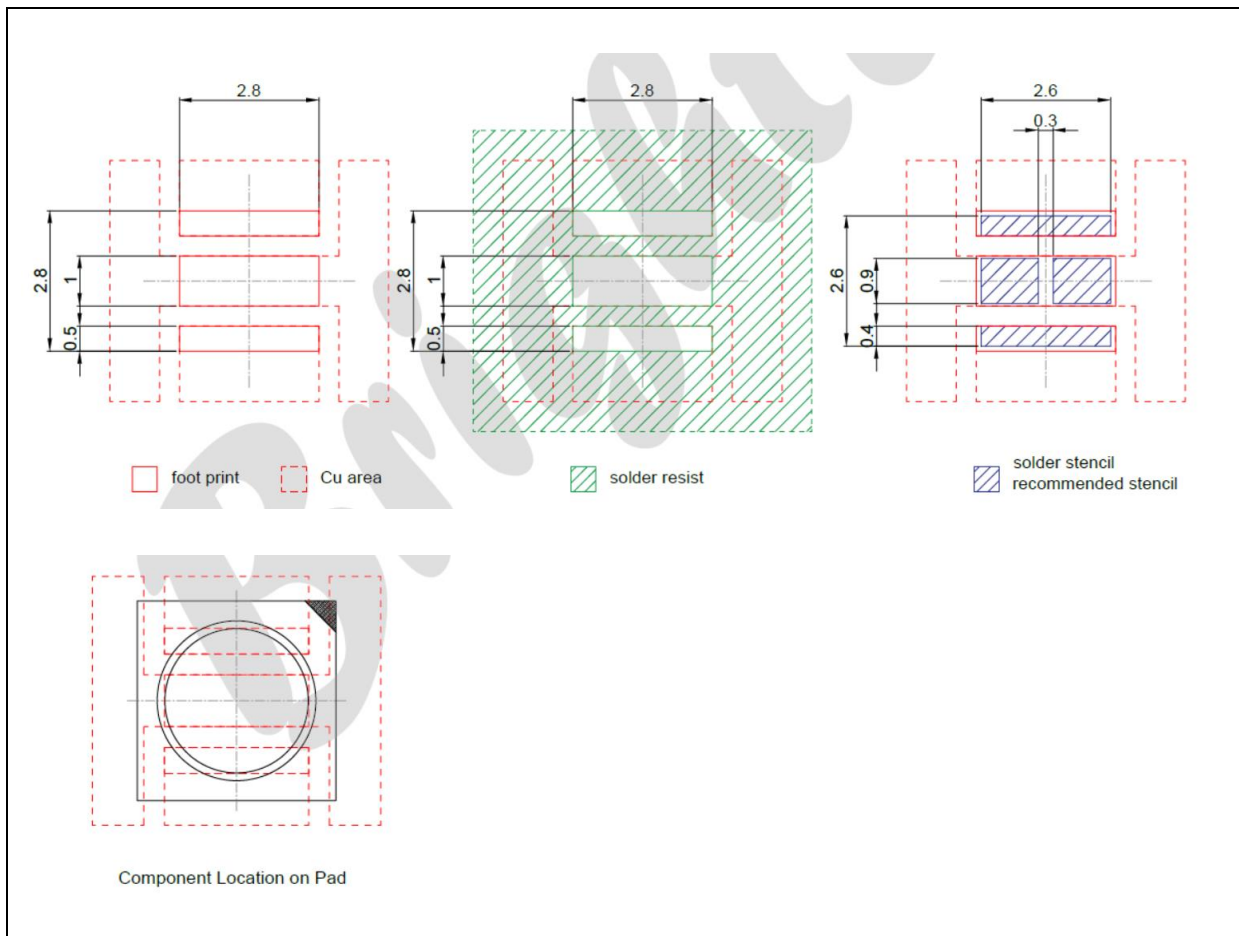

1. Dimensions are in millimetre (mm).
2. Tolerance  $\pm 0.1\text{mm}$  with angle tolerance  $\pm 0.5^\circ$ .

**BINNING GROUPS:**

---

 Forward Voltage Classifications ( $I_F=1A$ ;  $t_p=10ms$ ):

Code	Min.	Max.	Unit
DF	1.4	2.0	V

 Radiant Power Classifications ( $I_F=1A$ ;  $t_p=10ms$ ):

Code	Min.	Max.	Unit
PA7	700	800	mW
PA8	800	900	
PA9	900	1000	

 Peak Wavelength Classifications ( $I_F=1A$ ;  $t_p=10ms$ ):

Code	Min.	Max.	Unit
F1	930	950	nm

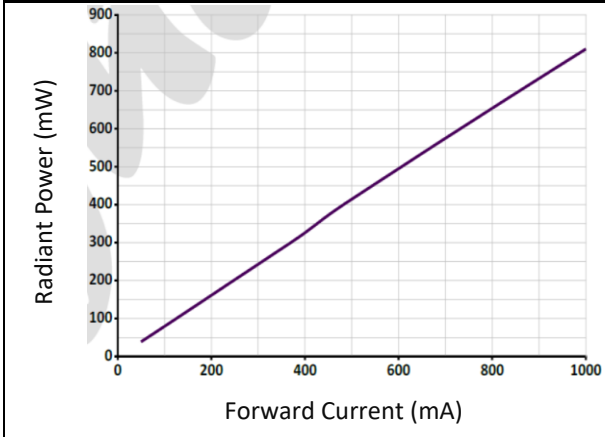
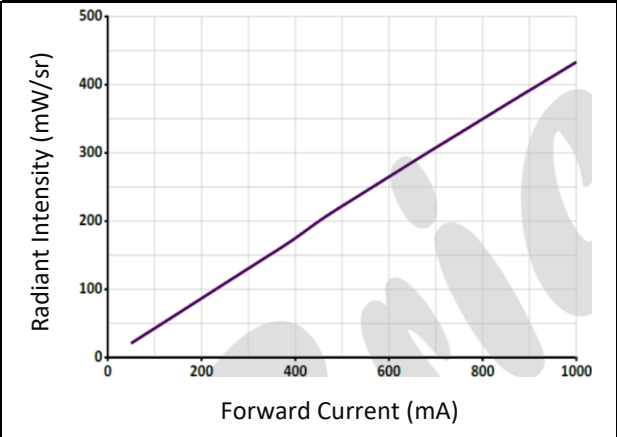
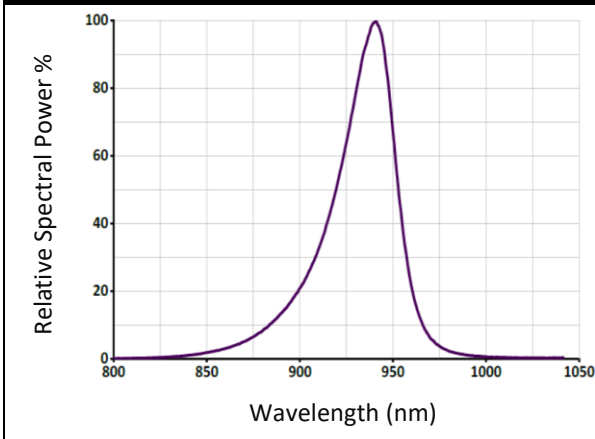
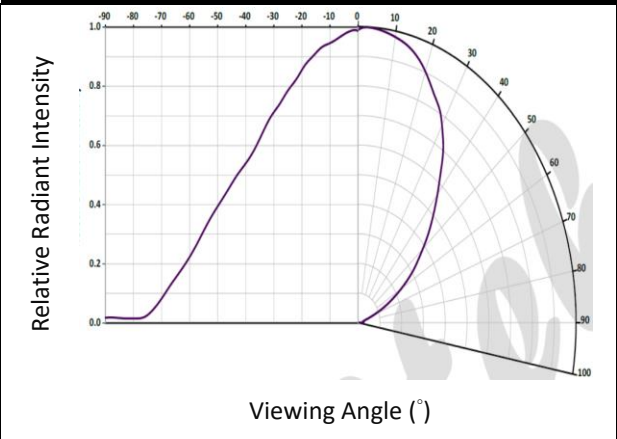
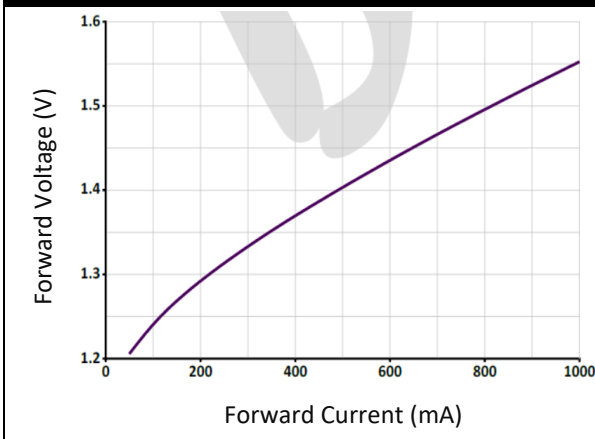
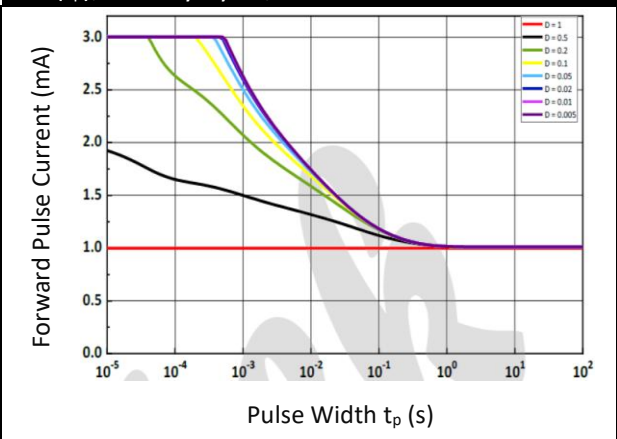
**ELECTRO-OPTICAL CHARACTERISTICS:**
**Radiant Power v.s. Forward Current**

**Radiant Intensity v.s. Forward Current**

**Relative Spectral Power v.s. Wavelength**

**Directive Radiation (L=0)**

**Forward Current v.s. Forward Voltage**

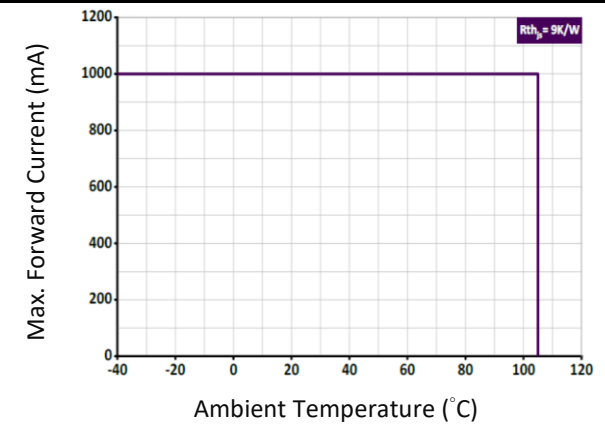
**Permissible Pulse Handling Capability**  
 $I_F = f(t_p)$ ;  $D = \text{Duty Cycle}$ ;  $T_s = 85^\circ\text{C}$ 

## ELECTRO-OPTICAL CHARACTERISTICS:

---

### Permissible Forward Current

$$I_{F(\max)} = f(T_s); R_{thjs} = 9K/W$$



## RECOMMENDED SOLDERING PROFILE:

Reflow Lead-free Solder:

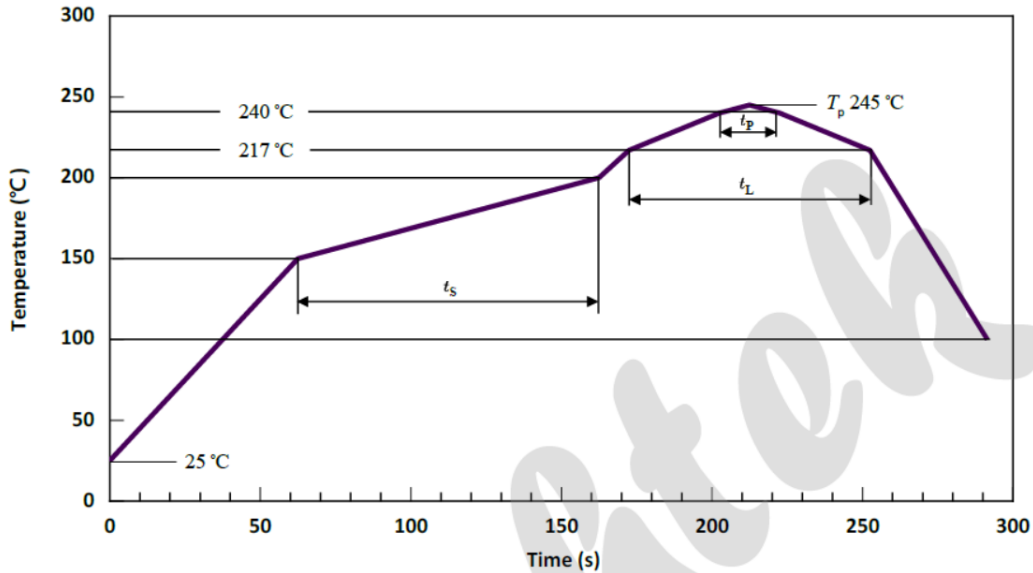

Profile Feature	Symbol	Pb-Free (SnAgCu) Assembly			Unit
		Minimum	Recommendation	Maximum	
Ramp-up rate to preheat 25 °C to 150 °C			2	3	K/s
Time $t_s$ $T_{smin}$ to $T_{smax}$	$t_s$	60	100	120	s
Ramp-up rate to peak $T_{smax}$ to $T_p$			2	3	K/s
Liquidus temperature	$T_L$		217		°C
Time above liquidus temperature	$t_L$		80	100	s
Peak temperature	$T_p$		245	260	°C
Time within 5 °C of the specified peak temperature $T_p - 5$ K	$T_p$	10	20	30	s
Ramp-down Rate $T_p$ to 100 °C			3	4	K/s
Time 25 °C to $T_p$				480	s

Note:

1. Maximum reflow soldering: 2 times.
2. Recommended soldering temperature is 245°C. The maximum soldering temperature should be limited to 260°C.
3. Before, during, and after soldering, should not apply stress on the components and PCB board.





## PRECAUTIONS OF USE:

---

### Storage:

It is recommended to store the products in the following conditions:

- Humidity: 60% R.H. Max.
- Temperature: 5°C~30°C (41°F ~86°F).

Shelf life in sealed bag: 12 months at 5°C~30°C and <60% R.H.

Once the package is opened, the products should be used within a week. Otherwise, they should be kept in a damp-proof box with desiccating agent <10% R.H. and apply baking before use.

### Baking:

It is recommended to bake the LED before soldering if the pack has been unsealed for longer than 24hrs. The suggested baking conditions are as followings:

- 60±3°C x 24hrs and <5%RH, taped / reel package.

It's normal to see slight color fading of carrier (light yellow) after baking in process.

### Testing Circuit:

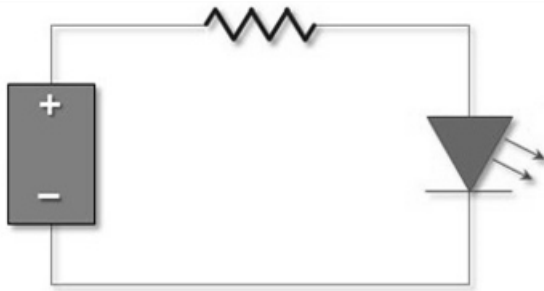

Must apply resistor(s) for protection (over current proof).

### Cleaning:

Use alcohol-based cleaning solvents such as isopropyl alcohol to clean the LED carrier / package. Avoid putting any stress force directly on to the LED lens.

### ESD (Electrostatic Discharge):

Static Electricity or power surge will damage the LED. Use of a conductive wrist band or anti-electrosatic glove is recommended when handling the LED all time. All devices, equipment, machinery, work tables, and storage racks must be properly grounded.

In the events of manual working in process, make sure the devices are well protected from ESD at any time.

**REVISION RECORD:**

---

Version	Date	Summary of Revision
A1.0	04/09/2024	Datasheet set-up.