



BRIGHTTEK
BRIGHTTEK (EUROPE) LIMITED

Brighten Up The World With LED!



ISO/TS 16949:2009



BS EN ISO 14001:2004



QC 080000 IECQ HSPM

PRODUCT DATASHEET



- ▶ EMC SMD Top View
- ▶ 3838 1.51t Series
- ▶ Infrared (IR) 940nm

NOF66S08BF



Release Date: 05 September 2024 Version: A1.1



3838 1.51t Series

RoHS Compliant



FEATURES:

- **Package:** Black Ceramic Single Junction SMT Package
- **Forward Current:** 1000mA
- **Pulse Forward Current (max.):** 3A
- **Forward Voltage (typ.):** 1.6V
- **Radiant Power (typ.):** 800mW@1A
- **Radiant Intensity (typ.):** 250mW/sr@1A
- **Colour:** Infrared (IR)
- **Peak Wavelength (typ.):** 940nm
- **Viewing Angle:** 150°
- **Operating Temperature:** -40~+105°C
- **Storage Temperature:** -40~+105°C
- **Grouping Parameters:**
 - Forward Voltage
 - Radiant Power
 - Peak Wavelength
- **Soldering Methods:** Reflow
- **MSL Level:** MSL 2 according to J-STD020
- **Corrosion Robustness Class:** 3B
- **Packing:** 12mm tape with max.800pcs/reel, ø178mm (7")

APPLICATIONS:

- Automotive
- Security Camera
- Motion Detection
- Night Viewer
- Surveillance
- Data Communication
- Facial Recognition
- Gesture Recognition

CHARACTERISTICS:

Absolute Maximum Characteristics ($T_a=25^{\circ}\text{C}$)

| Parameter | Symbol | Ratings | Unit |
|--|-----------|--------------------|--------------------|
| DC Forward Current | I_F | 1000 | mA |
| Pulse Forward Current | I_{PF} | 3 | A |
| Power Consumption | P_{tot} | 2 | W |
| Reverse Voltage | V_R | 5 | V |
| Reverse Current @5V | I_R | 10 | μA |
| Junction Temperature | T_j | 125 | $^{\circ}\text{C}$ |
| Thermal Resistance Junction to Solder Point | R_{th} | typ. 4.5 max. 9 | K/W |
| Electrostatic Discharge (HBM: MIL-STD-883 C 2) | ESD | 2 | kV |
| Operating Temperature | T_{OPR} | -40~+105 | $^{\circ}\text{C}$ |
| Storage Temperature | T_{STG} | -40~+105 | $^{\circ}\text{C}$ |
| Soldering Temperature | T_{SOL} | 260 | $^{\circ}\text{C}$ |

Electrical & Optical Characteristics ($T_a=25^{\circ}\text{C}$, $I_F=1\text{A}$, $t_p=10\text{ms}$)

| Parameter | Symbol | Values | | | Unit | Test Condition |
|--------------------|-----------------|--------|------|------|-------|---|
| | | Min. | Typ. | Max. | | |
| Forward Voltage | V_F | 1.4 | 1.6 | 2.0 | V | $I_F=1\text{A}$ $t_p=100\mu\text{s}$ |
| Radiant Power | Φ_e | 700 | 800 | 1000 | mW | $I_F=1\text{A}$ $t_p=100\mu\text{s}$ |
| Radiant Intensity | I_e | 180 | 250 | 320 | mW/sr | $I_F=1\text{A}$ $t_p=100\mu\text{s}$ |
| Peak Wavelength | λ_p | --- | 940 | --- | nm | $I_F=1\text{A}$ |
| Spectral Bandwidth | $\Delta\lambda$ | --- | 40 | --- | nm | $I_F=1\text{A}$ |
| Viewing Angle | $2\theta_{1/2}$ | --- | 150 | --- | deg | $I_F=1\text{A}$ |

1. Radiant Power (P_o) $\pm 10\%$, Forward Voltage (V_f) $\pm 0.1\text{V}$, Viewing angle($2\theta_{1/2}$) $\pm 10^{\circ}$

OUTLINE DIMENSION:

Package Dimension:

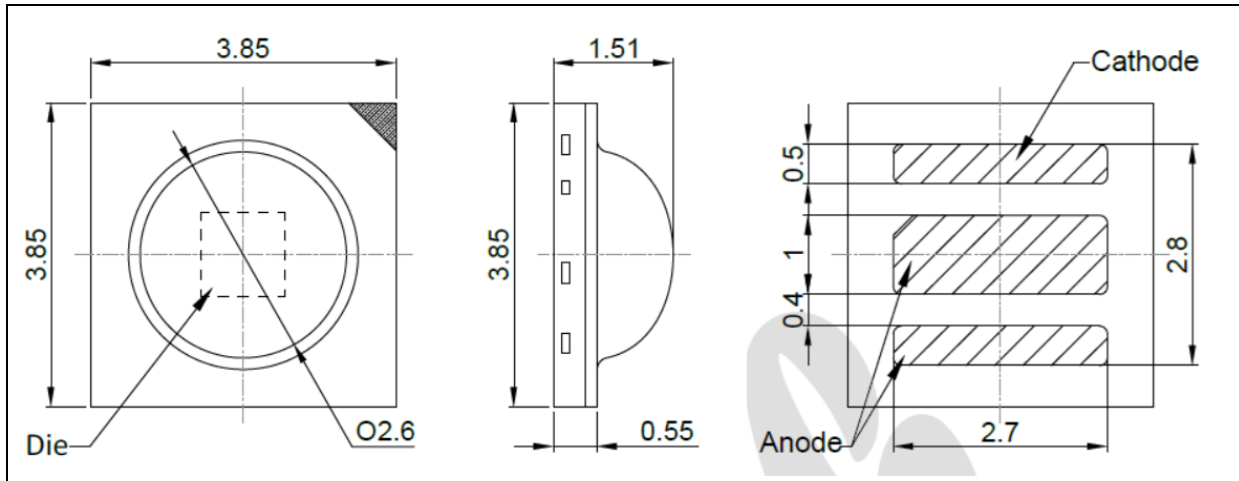

1. All dimensions are in millimetre (mm).
2. Tolerance $\pm 0.05\text{mm}$, unless otherwise noted.

Recommended Soldering Pad Dimension:

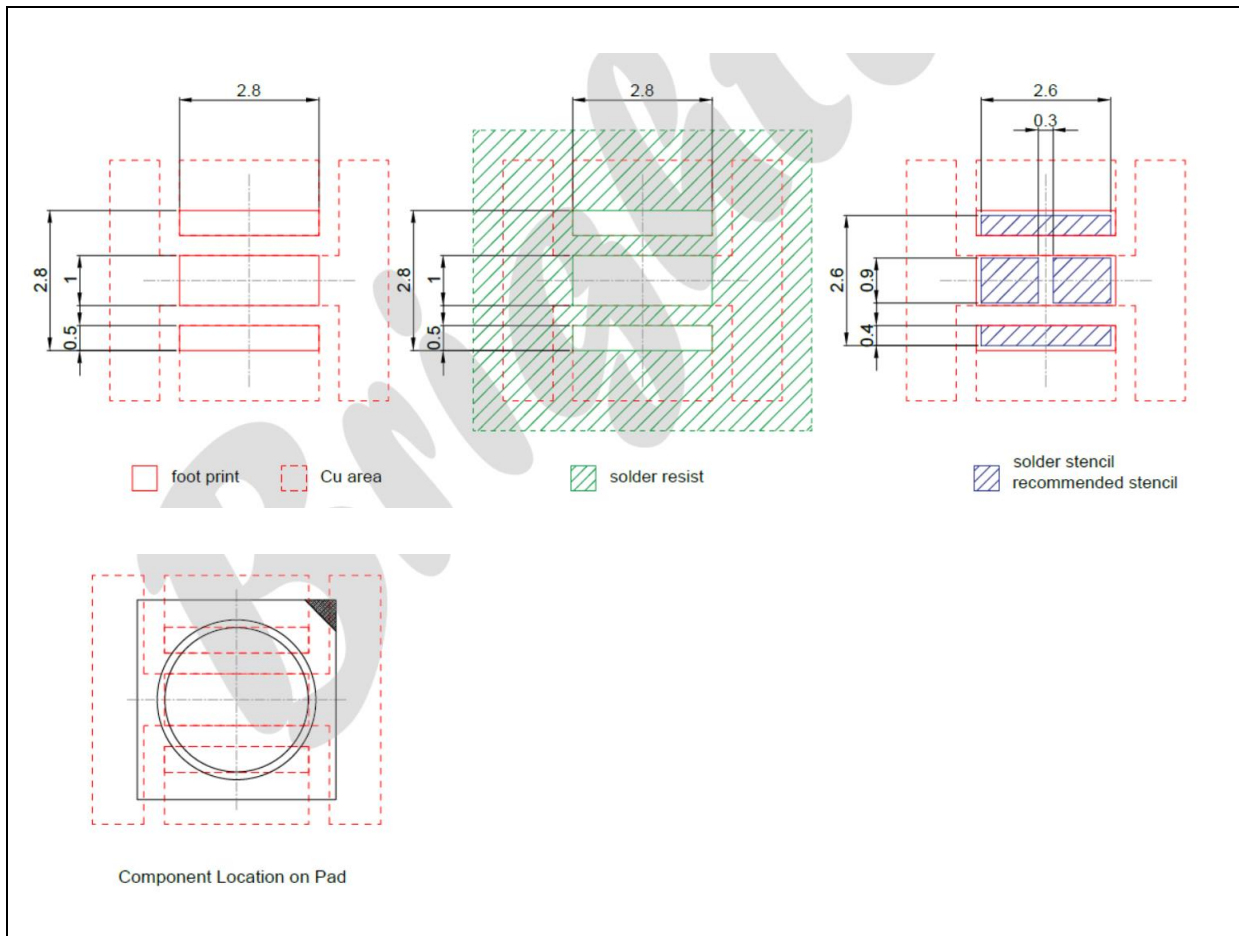

1. Dimensions are in millimetre (mm).
2. Tolerance $\pm 0.1\text{mm}$ with angle tolerance $\pm 0.5^\circ$.

BINNING GROUPS:

 Forward Voltage Classifications ($I_F = 1A$):

| Code | Min. | Max. | Unit |
|------|------|------|------|
| DF | 1.4 | 2.0 | V |

 Radiant Power Classifications ($I_F = 1A$):

| Code | Min. | Max. | Unit |
|------|------|------|------|
| PA7 | 700 | 800 | mW |
| PA8 | 800 | 900 | |
| PA9 | 900 | 1000 | |

 Peak Wavelength Classifications ($I_F = 1A$):

| Code | Min. | Max. | Unit |
|------|------|------|------|
| F1 | 930 | 950 | nm |

ELECTRO-OPTICAL CHARACTERISTICS:

Radiant Power v.s. Forward Current

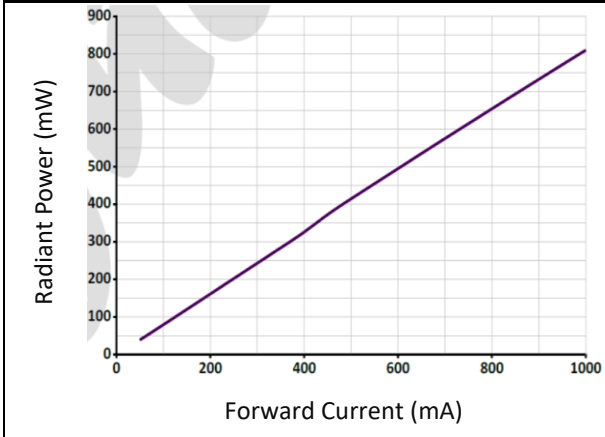

Radiant Intensity v.s. Forward Current

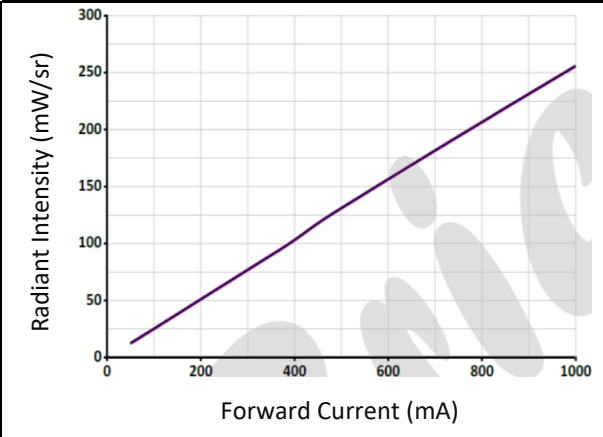

Relative Spectral Power v.s. Wavelength

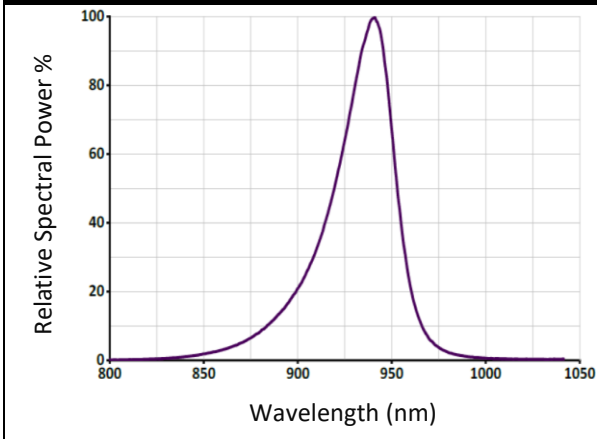

Directive Radiation

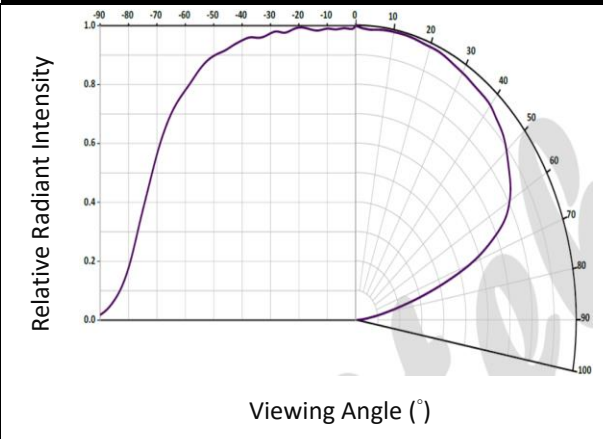

Forward Current v.s. Forward Voltage

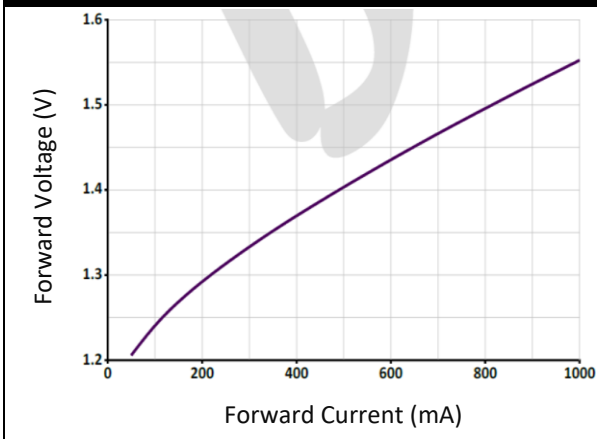

Permissible Pulse Handling Capability
 $I_F = f(t_p)$; $D = \text{Duty Cycle}$; $T_s = 85^\circ\text{C}$

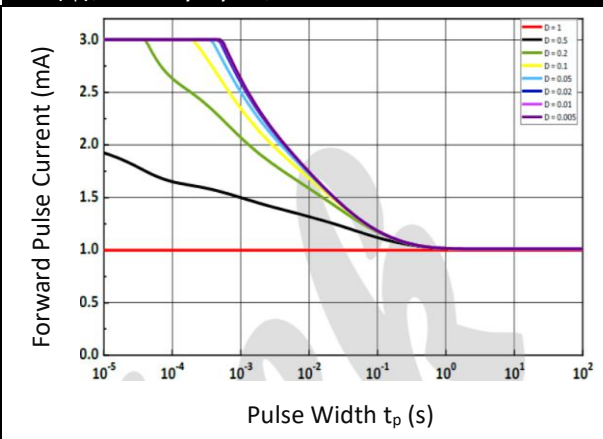

ELECTRO-OPTICAL CHARACTERISTICS:

Permissible Forward Current

$$I_{F(\max)} = f(T_s); R_{thjs} = 9K/W$$

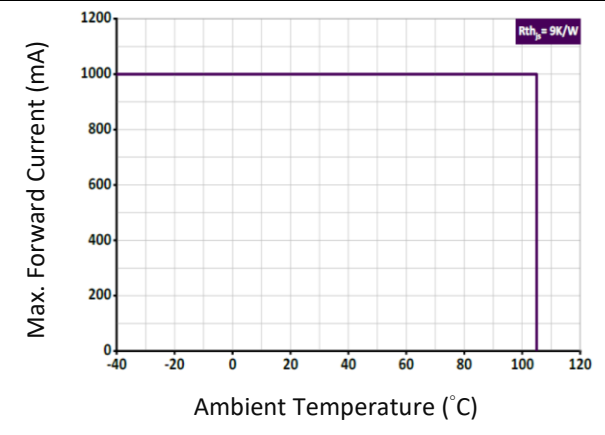



RECOMMENDED SOLDERING PROFILE:

Reflow Lead-free Solder:

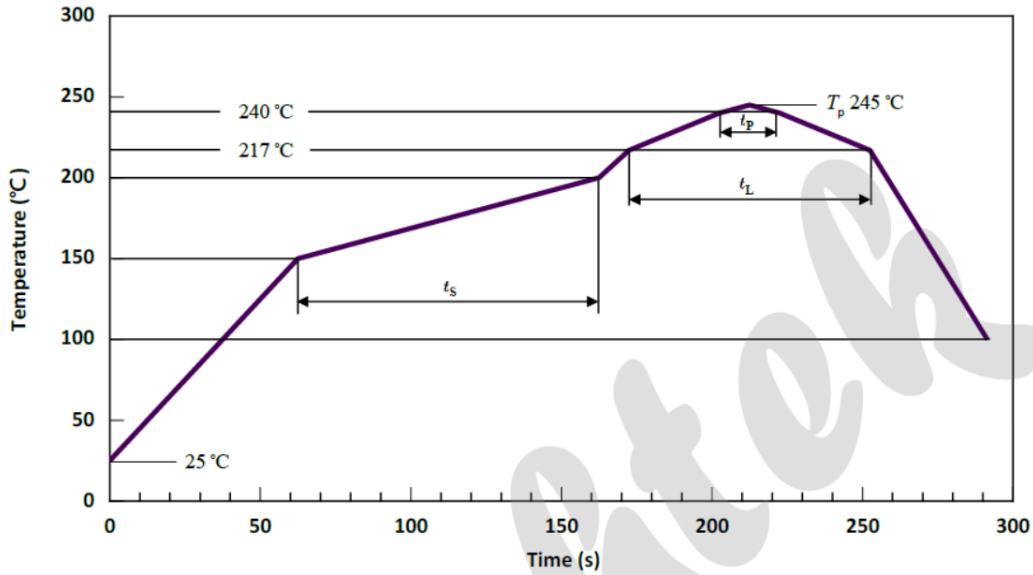

| Profile Feature | Symbol | Pb-Free (SnAgCu) Assembly | | | Unit |
|---|--------|---------------------------|----------------|---------|------|
| | | Minimum | Recommendation | Maximum | |
| Ramp-up rate to preheat 25 °C to 150 °C | | | 2 | 3 | K/s |
| Time t_s T_{smin} to T_{smax} | t_s | 60 | 100 | 120 | s |
| Ramp-up rate to peak T_{smax} to T_p | | | 2 | 3 | K/s |
| Liquidus temperature | T_L | | 217 | | °C |
| Time above liquidus temperature | t_L | | 80 | 100 | s |
| Peak temperature | T_p | | 245 | 260 | °C |
| Time within 5 °C of the specified peak temperature $T_p - 5 K$ | T_p | 10 | 20 | 30 | s |
| Ramp-down Rate T_p to 100 °C | | | 3 | 4 | K/s |
| Time 25 °C to T_p | | | | 480 | s |

Note:

1. Maximum reflow soldering: 2 times.
2. Recommended soldering temperature is 245°C. The maximum soldering temperature should be limited to 260°C.
3. Before, during, and after soldering, should not apply stress on the components and PCB board.

PACKING SPECIFICATION:

Reel Dimension:

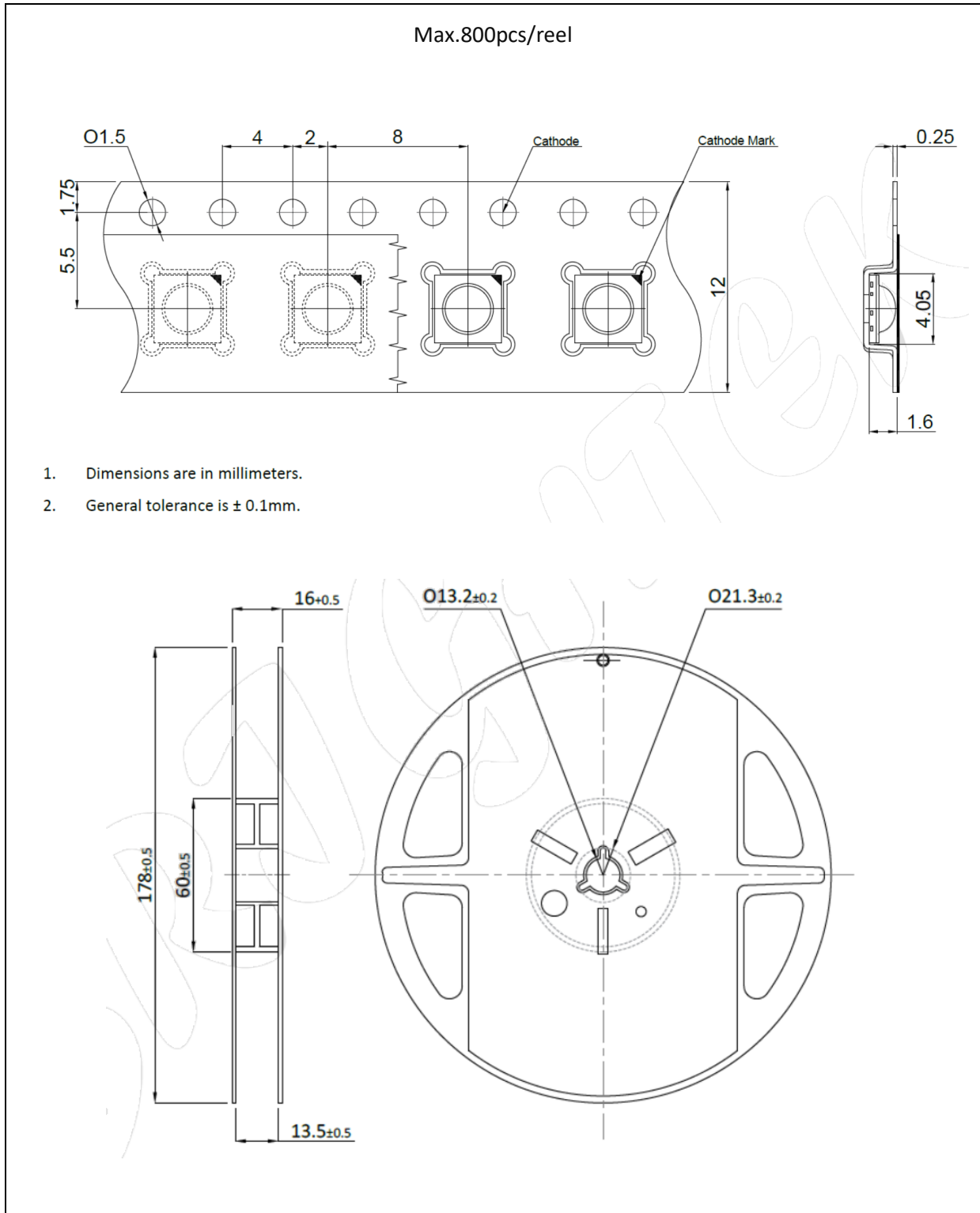

PRECAUTIONS OF USE:

Storage:

It is recommended to store the products in the following conditions:

- Humidity: 60% R.H. Max.
- Temperature: 5°C~30°C (41°F ~86°F).

Shelf life in sealed bag: 12 months at 5°C~30°C and <60% R.H.

Once the package is opened, the products should be used within a week. Otherwise, they should be kept in a damp-proof box with desiccating agent <10% R.H. and apply baking before use.

Baking:

It is recommended to bake the LED before soldering if the pack has been unsealed for longer than 24hrs. The suggested baking conditions are as followings:

- 60±3°C x 24hrs and <5%RH, taped / reel package.

It's normal to see slight color fading of carrier (light yellow) after baking in process.

Testing Circuit:

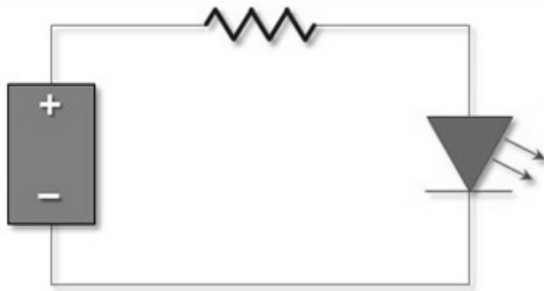

Must apply resistor(s) for protection (over current proof).

Cleaning:

Use alcohol-based cleaning solvents such as isopropyl alcohol to clean the LED carrier / package. Avoid putting any stress force directly on to the LED lens.

ESD (Electrostatic Discharge):

Static Electricity or power surge will damage the LED. Use of a conductive wrist band or anti-electrostatic glove is recommended when handling the LED all time. All devices, equipment, machinery, work tables, and storage racks must be properly grounded.

In the events of manual working in process, make sure the devices are well protected from ESD at any time.

REVISION RECORD:

| Version | Date | Summary of Revision |
|---------|------------|-----------------------------|
| A1.0 | 05/03/2024 | Datasheet set-up. |
| A1.1 | 05/09/2024 | Revise radiant power level. |