



**BRIGHTTEK**  
**BRIGHTTEK (EUROPE) LIMITED**

*Brighten up The World With LED!*



ISO/TS 16949:2009



BS EN ISO 14001:2004



QC 080000 IECQ HSPM

## PRODUCT DATASHEET



- ▶ DC Input Photo Coupler
- ▶ LSOP4
- ▶ Photo Transistor

Release Date: 04 April 2025  
 Version: B00

# TD101X(T1)-GV



## TD101X Series

### DESCRIPTION:



The TD101X series combine an AlGaAs infrared emitting diode as the emitter which is optically coupled to a silicon planar phototransistor detector in a plastic LSOP4 package.

With the robust coplanar double mold structure, TD101X series provide the most stable isolation feature.

### FEATURES:

- High isolation 5000 Vrms
- DC input with transistor output
- Operating temperature range -55°C to +110°C
- MSL class 1
- Regulatory Approvals:
  - UL - UL1577
  - VDE - EN60747-5-5 (VDE0884-5)
  - CQC - GB4943.1, GB8898
  - cUL - CSA Component Acceptance Service Notice 5A
- Packing: 3000pcs/reel

### APPLICATIONS:

- Switch mode power supplies
- Programmable controllers
- Household appliances
- Office equipment



Partner with: LIGHTNING

**NAMING & ORDERING INFORMATION:**

Naming Information:

<b>TD101 X (T1) - G V</b>	
<b>TD101</b>	Part Number
<b>X</b>	Selection: CTR (0~9)
<b>T1</b>	Selection: Tape and Reel Option (T1(default)/T2)
<b>G</b>	Green Option
<b>V</b>	VDE Option

Ordering Information:

<b>TD101X(T1)-GV</b>						
<u>X</u> = Selection: CTR (0~9)						
Part Number	Symbol	Values			Unit	Test Condition
		Min.	Typ.	Max.		
TD1010(T1)-GV	CTR	300	---	600	%	I <sub>F</sub> =5mA, V <sub>CE</sub> =5V
TD1011(T1)-GV		60	---	300	%	I <sub>F</sub> =10mA, V <sub>CE</sub> =5V
TD1012(T1)-GV		63 (22)	---	125	% (I <sub>F</sub> =10mA, V <sub>CE</sub> =5V (I <sub>F</sub> =1mA, V <sub>CE</sub> =5V))	
TD1013(T1)-GV		100 (34)	---	200		
TD1014(T1)-GV		160 (56)	---	320		
TD1015(T1)-GV		50	---	150	% (I <sub>F</sub> =5mA, V <sub>CE</sub> =5V)	
TD1016(T1)-GV		100	---	300		
TD1017(T1)-GV		80	---	160		
TD1018(T1)-GV		130	---	260		
TD1019(T1)-GV		200	---	400		

Version No.	Original Release Date
Rev: B00	10/10/2024

## SCHEMATIC DIAGRAM & MARKING:

Schematic Diagram:

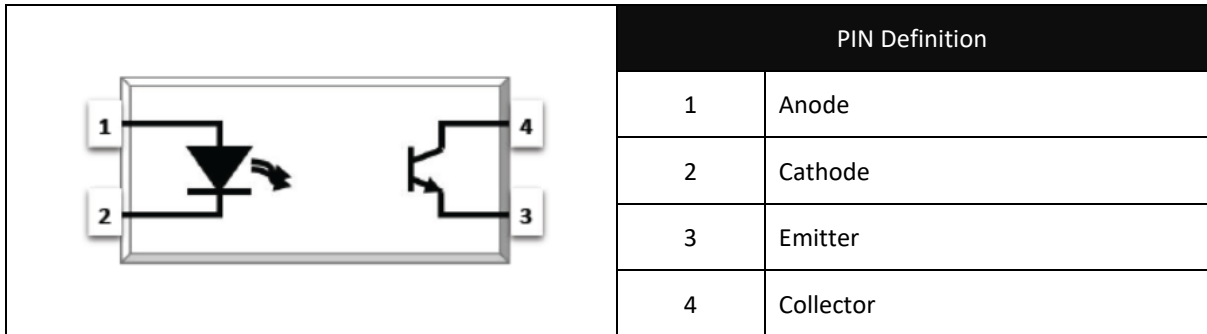

Marking Information:

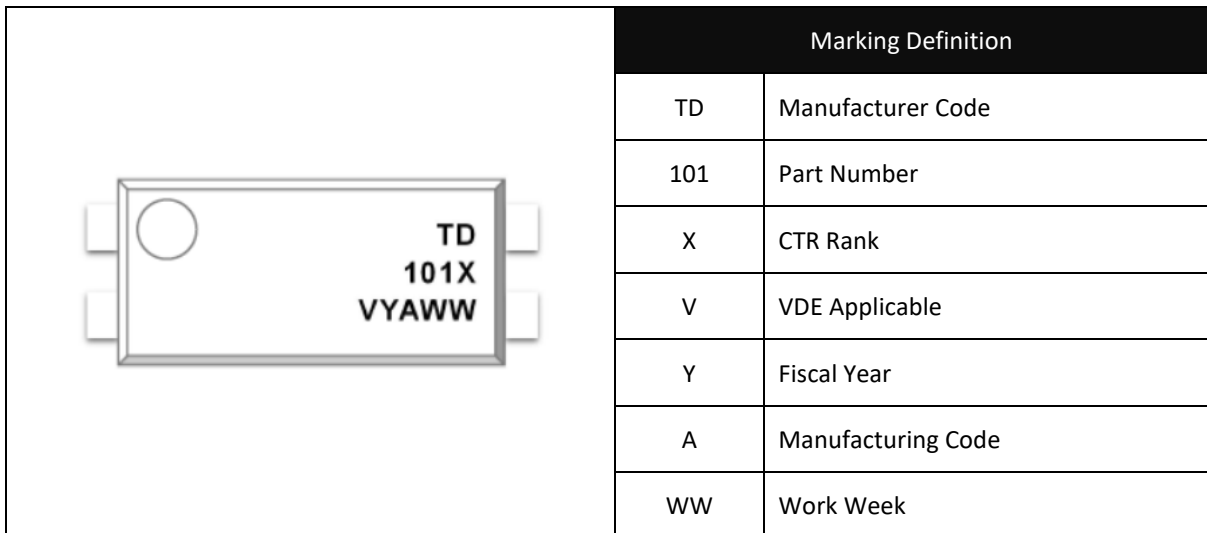

Labelling Information:

 <p>福建天电光电有限公司        FUJIAN LIGHTNING OPTOELECTRONIC CO.,LTD        Part No.:XXXXXXXXX Bin Code: X        Lot No.: XXXXXXXXXXXX        Date Code: XXXX        QTY: XXX PCS        MSL: 1        Made in Quanzhou Fujian</p>	<p>This product is manufactured, tested, and packed by</p>
	

**ABSOLUTE CHARACTERISTICS:**

## Absolute Maximum Ratings:

Parameter	Symbol	Ratings	Unit
INPUT			
Forward Current	$I_F$	60	mA
Peak Forward Current	$I_{FP}$	1 * <sup>1</sup>	A
Reverse Voltage	$V_R$	6	V
Input Power Dissipation	$P_i$	100	mW
OUTPUT			
Collector - Emitter Voltage	$V_{CEO}$	80	V
Emitter - Collector Voltage	$V_{ECO}$	7	V
Collector Current	$I_c$	50	mA
Output Power Dissipation	$P_o$	150	mW
COMMON			
Total Power Dissipation	$P_{tot}$	200	mW
Isolation Voltage	$V_{iso}$	5000 * <sup>2</sup>	V <sub>rms</sub>
Operating Temperature	$T_{opr}$	-55~+110	°C
Storage Temperature	$T_{stg}$	-55~+125	°C
Soldering Temperature	$T_{sol}$	260 * <sup>3</sup>	°C

\*1. 100µs pulse, 100Hz frequency

\*2. AC for 1 minute, R.H.=40~60%

\*3. For 10 seconds max.

**ELECTRICAL CHARACTERISTICS:**

Electrical Optical Characteristics at Ta=25°C:

Parameter	Symbol	Values			Unit	Test Condition	
		Min.	Typ.	Max.			
INPUT							
Forward Voltage	V <sub>F</sub>	---	1.24	1.4	V	I <sub>F</sub> =10mA	
Reverse Current	I <sub>R</sub>	---	---	10	μA	V <sub>R</sub> =6V	
Input Capacitance	C <sub>IN</sub>	---	30	250	pF	V=0, f=1kHz	
OUTPUT							
Collector Dark Current	I <sub>CEO</sub>	---	---	100	nA	I <sub>F</sub> =0mA, V <sub>CE</sub> =20V	
Collector - Emitter Breakdown Voltage	BV <sub>CEO</sub>	80	---	---	V	I <sub>C</sub> =0.1mA, I <sub>F</sub> =0mA	
Emitter - Collector Breakdown Voltage	BV <sub>ECO</sub>	6	---	---	V	I <sub>E</sub> =0.1mA, I <sub>F</sub> =0mA	
TRANSFER CHARACTERISTICS							
Current Transfer Rate	TD1010	CTR	300	---	600	%	I <sub>F</sub> =5mA, V <sub>CE</sub> =5V
	TD1011		60	---	300	%	I <sub>F</sub> =10mA, V <sub>CE</sub> =5V
	TD1012		63 (22)	---	125	%	I <sub>F</sub> =10mA, V <sub>CE</sub> =5V (I <sub>F</sub> =1mA, V <sub>CE</sub> =5V)
	TD1013		100 (34)	---	200		
	TD1014		160 (56)	---	320		
	TD1015		50	---	150	%	I <sub>F</sub> =5mA, V <sub>CE</sub> =5V
	TD1016		100	---	300		
	TD1017		80	---	160		
	TD1018		130	---	260		
	TD1019		200	---	400		
Collector-Emitter Saturation Voltage	V <sub>CE(sat)</sub>	---	0.1	0.3	V	I <sub>F</sub> =10mA, I <sub>C</sub> =1mA	
Isolation Resistance	R <sub>ISO</sub>	10 <sup>12</sup>	10 <sup>14</sup>	---	Ω	DC=500V, 40~60% R.H.	
Floating Capacitance	C <sub>IO</sub>	---	0.4	1	pF	V=0, f=1MHz	
Response Time (Rise)	t <sub>r</sub>	---	5	18	μs	V <sub>CE</sub> =2V, I <sub>C</sub> =2mA R <sub>L</sub> =100Ω	
Response Time (Fall)	t <sub>f</sub>	---	6	18	μs		
Cut-off Frequency	f <sub>c</sub>	---	80	---	kHz	V <sub>CE</sub> =2V, I <sub>C</sub> =2mA R <sub>L</sub> =100Ω, -3dB	

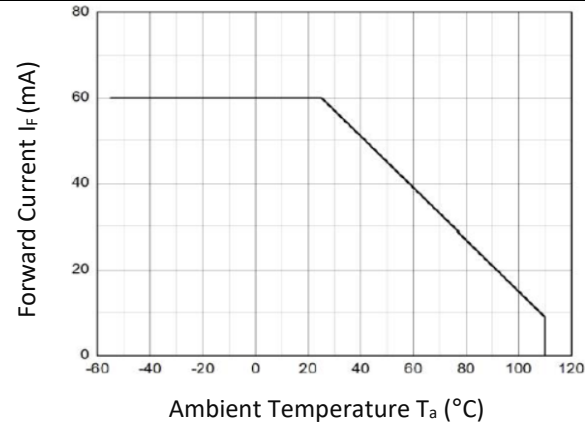
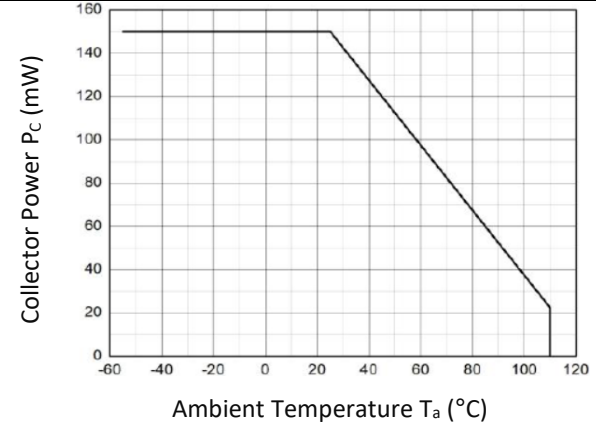
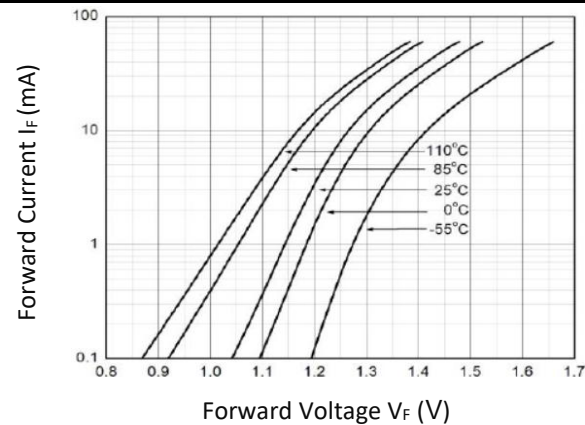
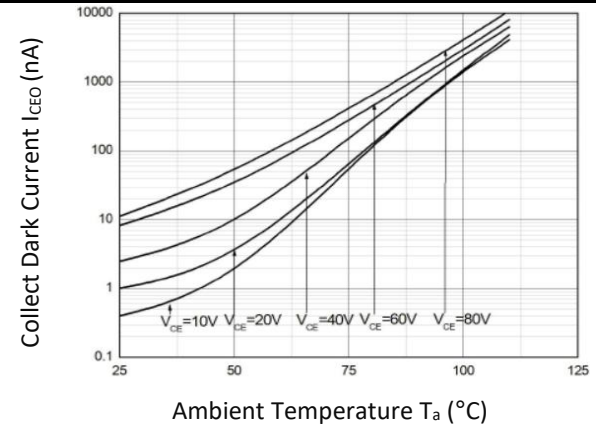
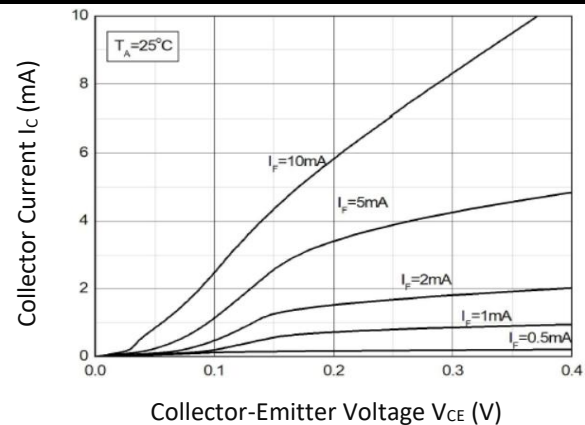
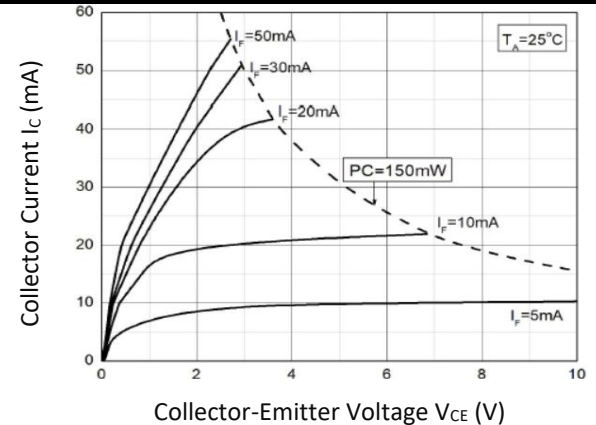
**CHARACTERISTIC CURVES:**
**Forward Current v.s. Ambient Temperature**

**Collector Power Dissipation v.s. Ambient Temp.**

**Forward Current v.s. Forward Voltage**

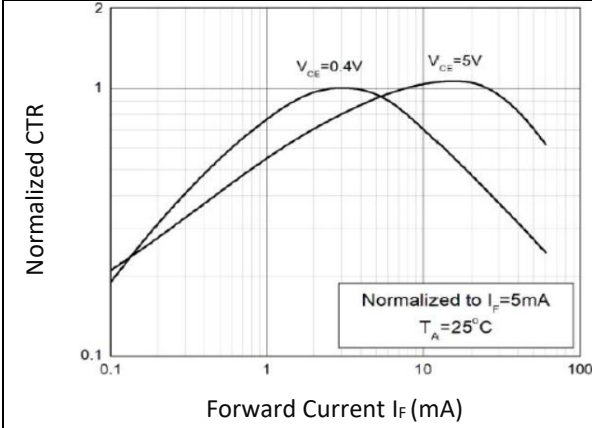
**Collector Dark Current v.s. Ambient Temperature**

**Collector Current v.s. Collector-Emitter Voltage**

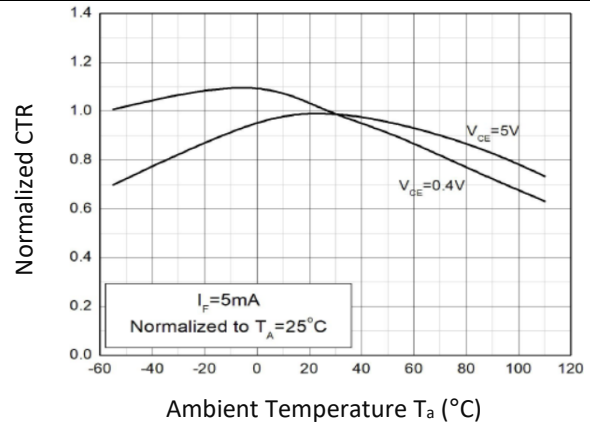
**Collector Current v.s. Collector-Emitter Voltage**

## CHARACTERISTIC CURVES:

Normalized Current Transfer Ratio v.s. Forward Current



Normalized Current Transfer Ratio v.s. Ambient Temperature



Collector-Emitter Saturation Voltage v.s. Ambient Temperature

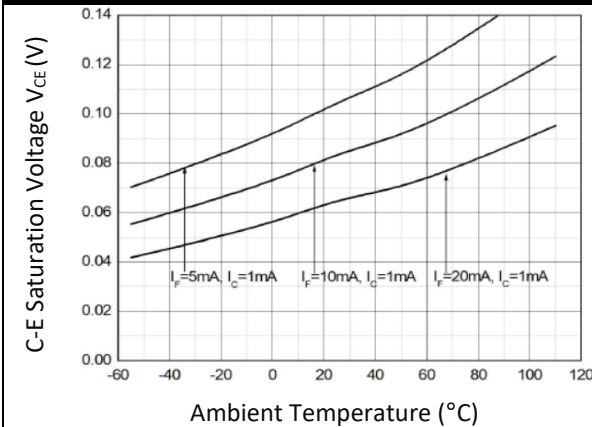

Switching Time v.s. Load Resistance

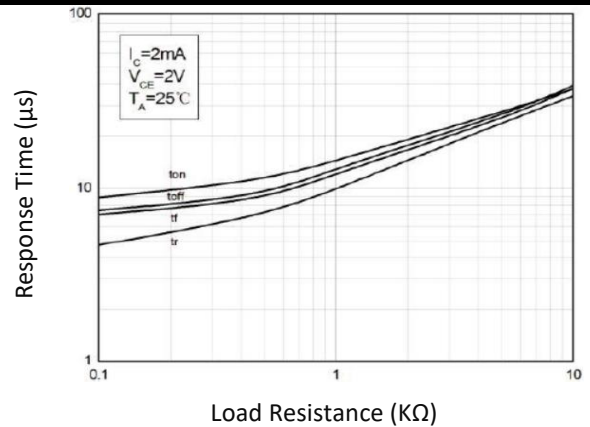

Frequency Response

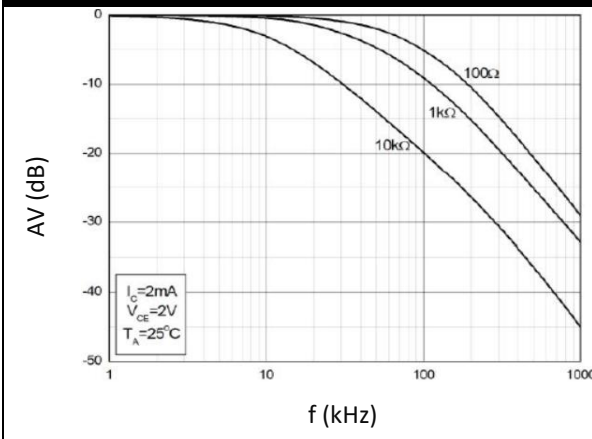

**TEST CIRCUIT:**

## Test Circuit of Response Time:

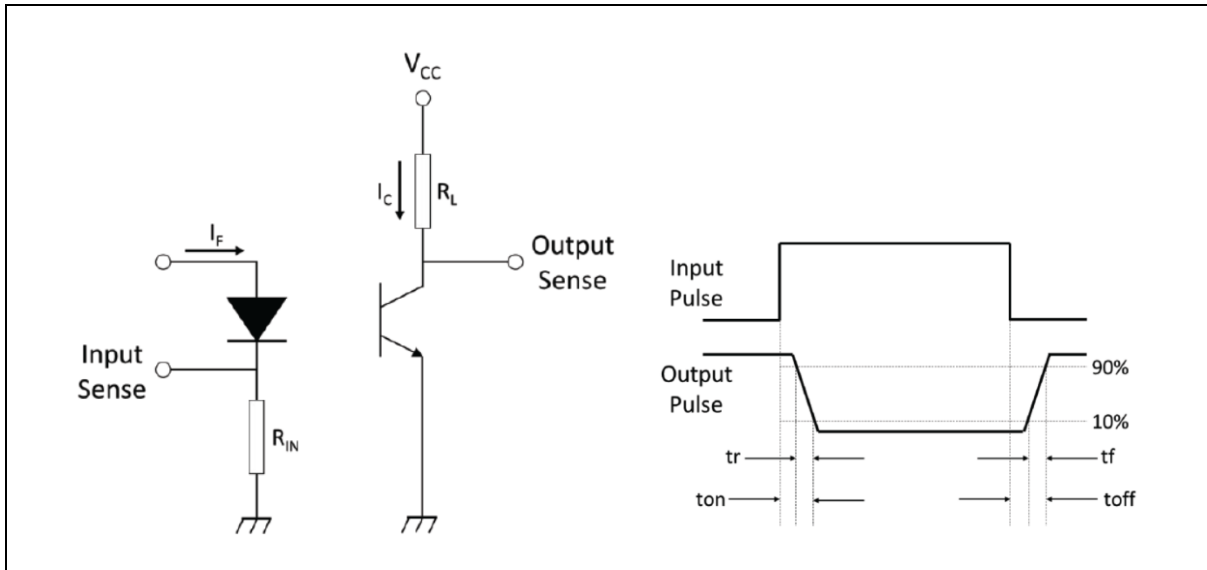

## Test Circuit of Frequency Response:

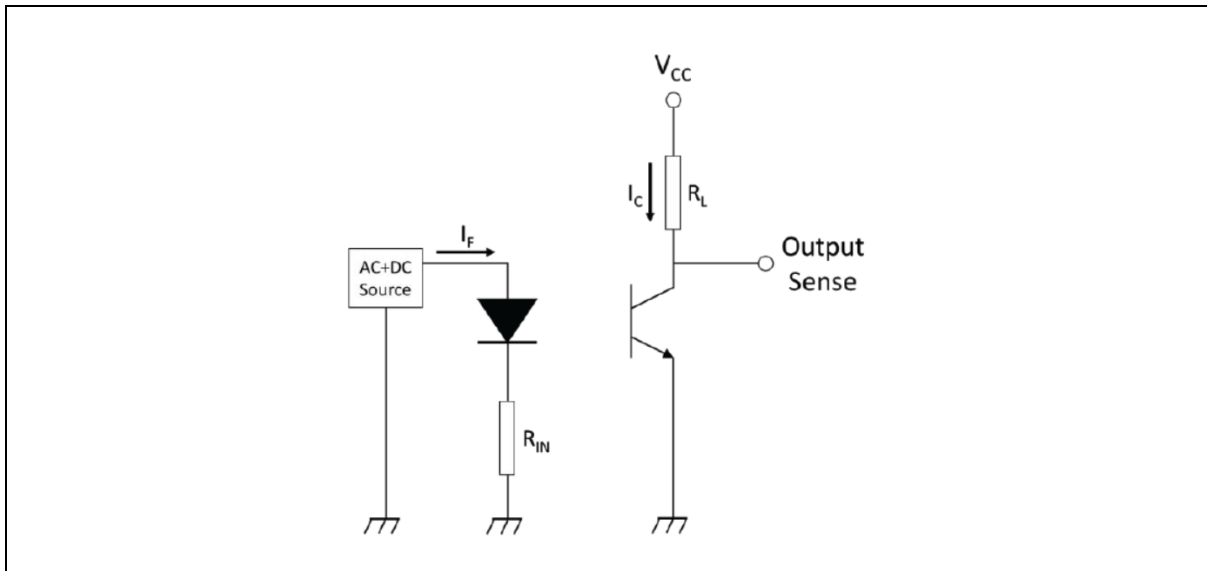



## OUTLINE DIMENSION:

Package Dimension:

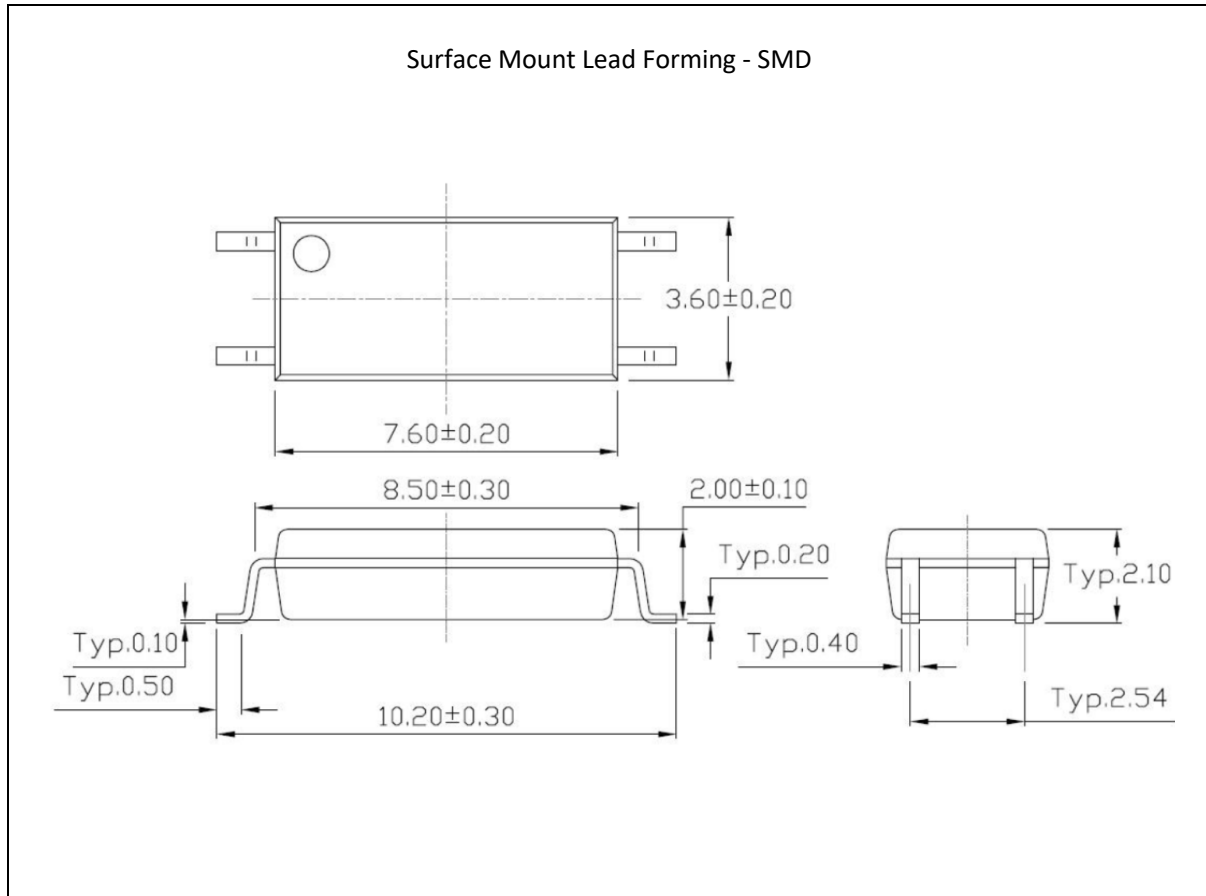

1. All dimensions are in millimetre (mm).

Recommended Soldering Mask:

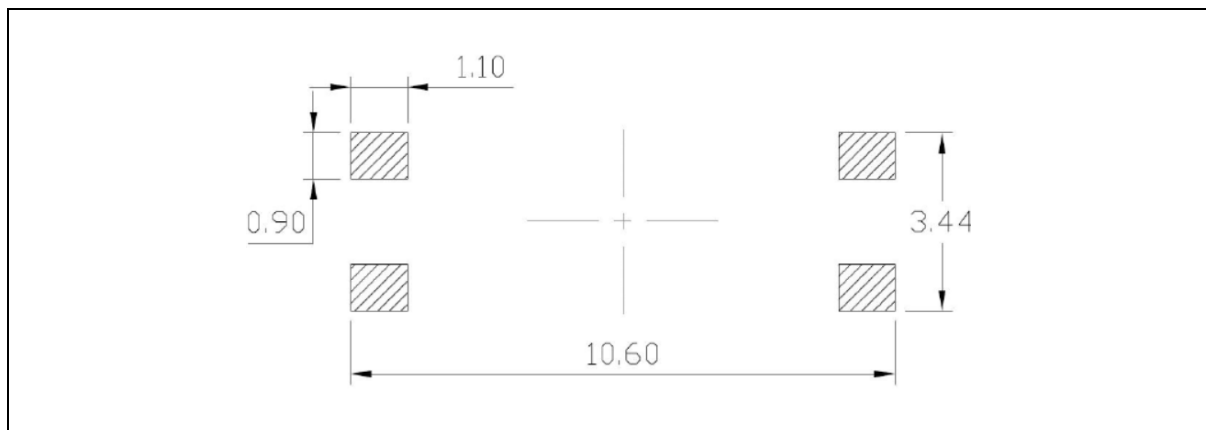

1. Dimensions are in millimetre (mm).

**PACKING SPECIFICATION:**

Reel Dimension:

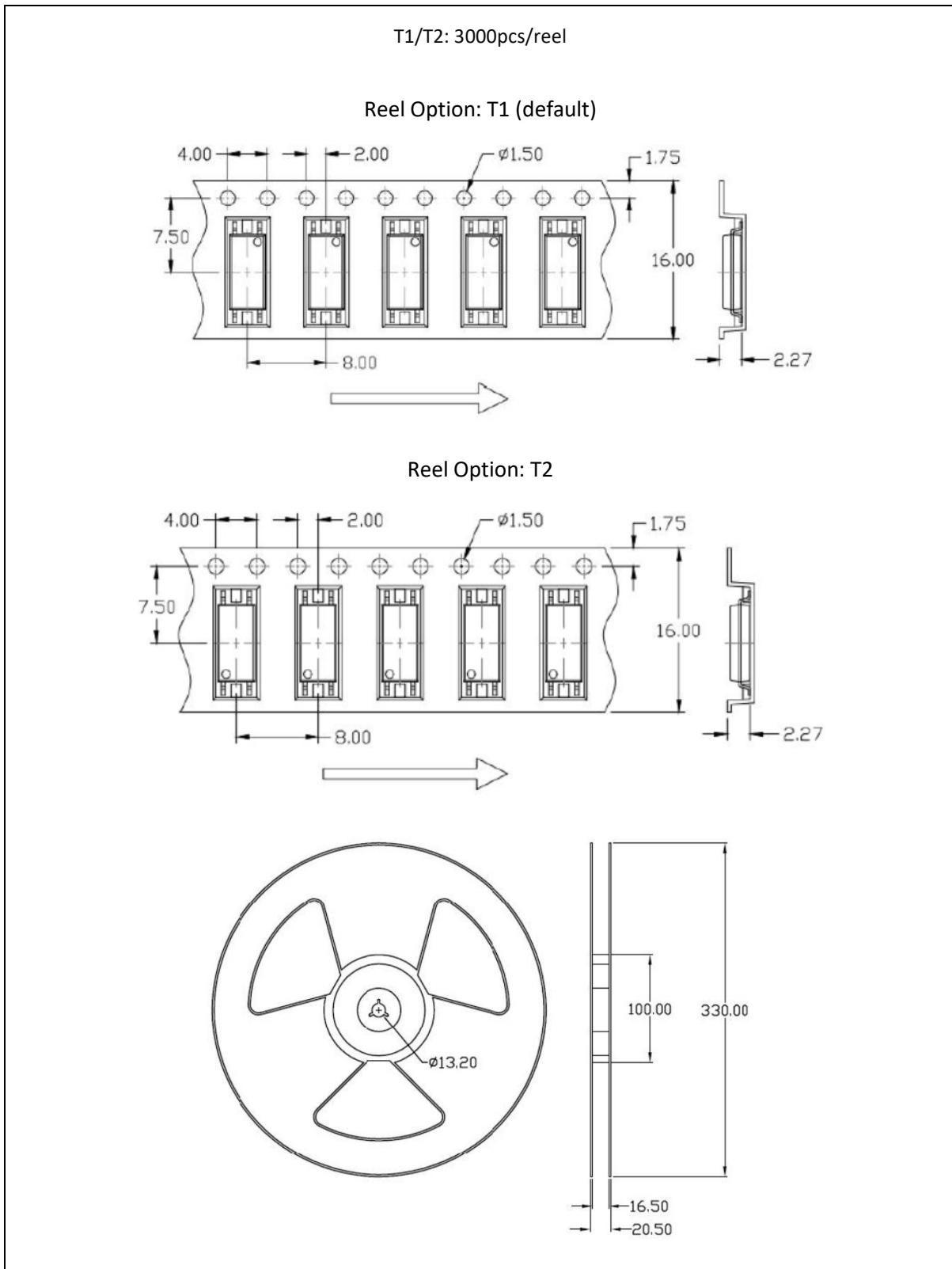

**PACKING SPECIFICATION:**

Box Dimension:

3 reel (9Kpcs)/inner box, 5 inner box (45Kpcs)/carton

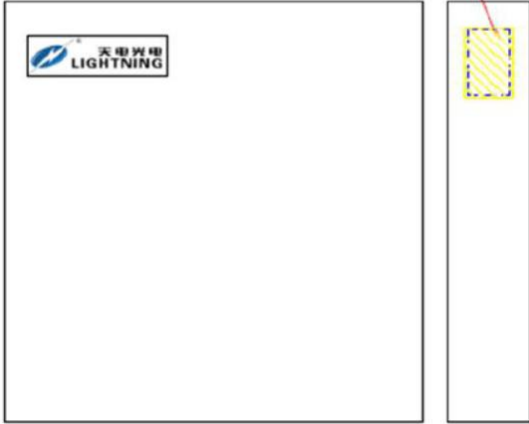

Label

- L x W x H = 36cm x 36cm x 6.9cm

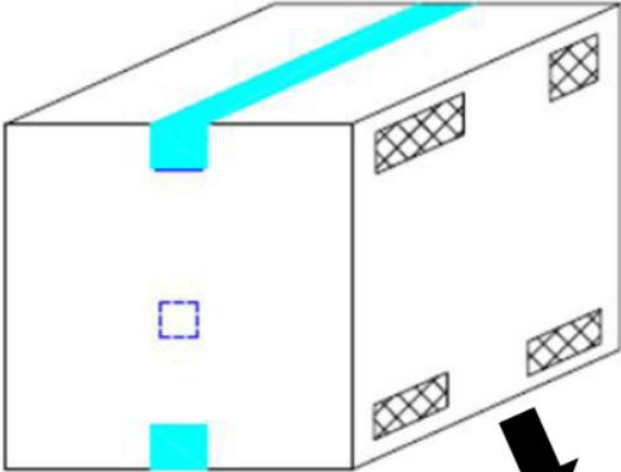

Label

- L x W x H = 45cm x 38cm x 38cm



## RECOMMENDED SOLDERING PROFILE:

Reflow Information:

