



BRIGHTTEK
BRIGHTTEK (EUROPE) LIMITED

Brighten up The World With LED!



ISO/TS 16949:2009



BS EN ISO 14001:2004



QC 080000 IECQ HSPM

PRODUCT DATASHEET



- ▶ Ceramic SMD
- ▶ 1616 0.82t Series
- ▶ Infrared (IR) 850nm

NOF66S39



Release Date: 06 August 2024 Version: A1.0



1616 0.82t Series

RoHS Compliant



**AUTOMOTIVE
AEC-Q102**

FEATURES:

- **Package:** Ceramic Dual Junction SMT Package
- **Forward Current:** 1A
- **Forward Voltage (typ.):** 3.3V
- **Radiant Power (typ.):** 1200mW@1A
- **Radiant Intensity (typ.):** 380mW/sr@1A
- **Colour:** Infrared (IR)
- **Peak Wavelength (typ.):** 850nm
- **Viewing Angle:** 130°
- **Materials:**
 - Resin: Silicon (Water Clear)
- **Operating Temperature:** -40~+105°C
- **Storage Temperature:** -40~+105°C
- **Grouping Parameters:**
 - Forward Voltage
 - Radiant Power
 - Peak Wavelength
- **Soldering Methods:** Reflow
- **MSL Level:** MSL 1 according to J-STD020
- **Corrosion Robustness Class:** A
- **Packing:** 8mm tape with max.2000pcs /reel, ø178mm (7")

APPLICATIONS:

- Automotive
- Security Camera
- Motion Detection
- Night Viewer
- Surveillance
- Data Communication
- Facial Recognition
- Gesture Recognition

CHARACTERISTICS:

Absolute Maximum Characteristics (Ta=25°C)

Parameter	Symbol	Ratings	Unit
DC Forward Current	I_F	1	A
Pulse Forward Current	I_{PF}	2	A
Power Consumption	P_{tot}	3.6	W
Reverse Voltage	V_R	5	V
Reverse Current @5V	I_R	10	μA
Junction Temperature	T_j	145	$^{\circ}C$
Thermal Resistance Junction	R_{th}	typ. 9 max. 12	K/W
Electrostatic Discharge (HBM: MIL-STD-883 C 2)	ESD	2	kV
Operating Temperature	T_{OPR}	-40~+105	$^{\circ}C$
Storage Temperature	T_{STG}	-40~+105	$^{\circ}C$
Soldering Temperature	T_{SOL}	260	$^{\circ}C$

1. When drive on maximum current, Junction temperature must be kept below 145°C.

Electrical & Optical Characteristics (Ta=25°C, $I_F=1A$, $t_p=10ms$)

Parameter	Symbol	Values			Unit	Test Condition
		Min.	Typ.	Max.		
Forward Voltage	V_F	2.9	3.3	3.6	V	$I_F=1A$
Radiant Power	Φ_e	1000	1200	1400	mW	$I_F=1A$
Radiant Intensity	I_e	280	380	480	mW/sr	$I_F=1A$
Peak Wavelength	λ_p	---	850	---	nm	$I_F=1A$
Spectral Bandwidth	$\Delta\lambda$	---	40	---	nm	$I_F=1A$
Viewing Angle	$2\theta_{1/2}$	---	130	---	deg	$I_F=1A$

2. Radiant Power (P_o) $\pm 10\%$, Forward Voltage (V_f) $\pm 0.1V$, Viewing angle($2\theta_{1/2}$) $\pm 10^{\circ}$

OUTLINE DIMENSION:

Package Dimension:

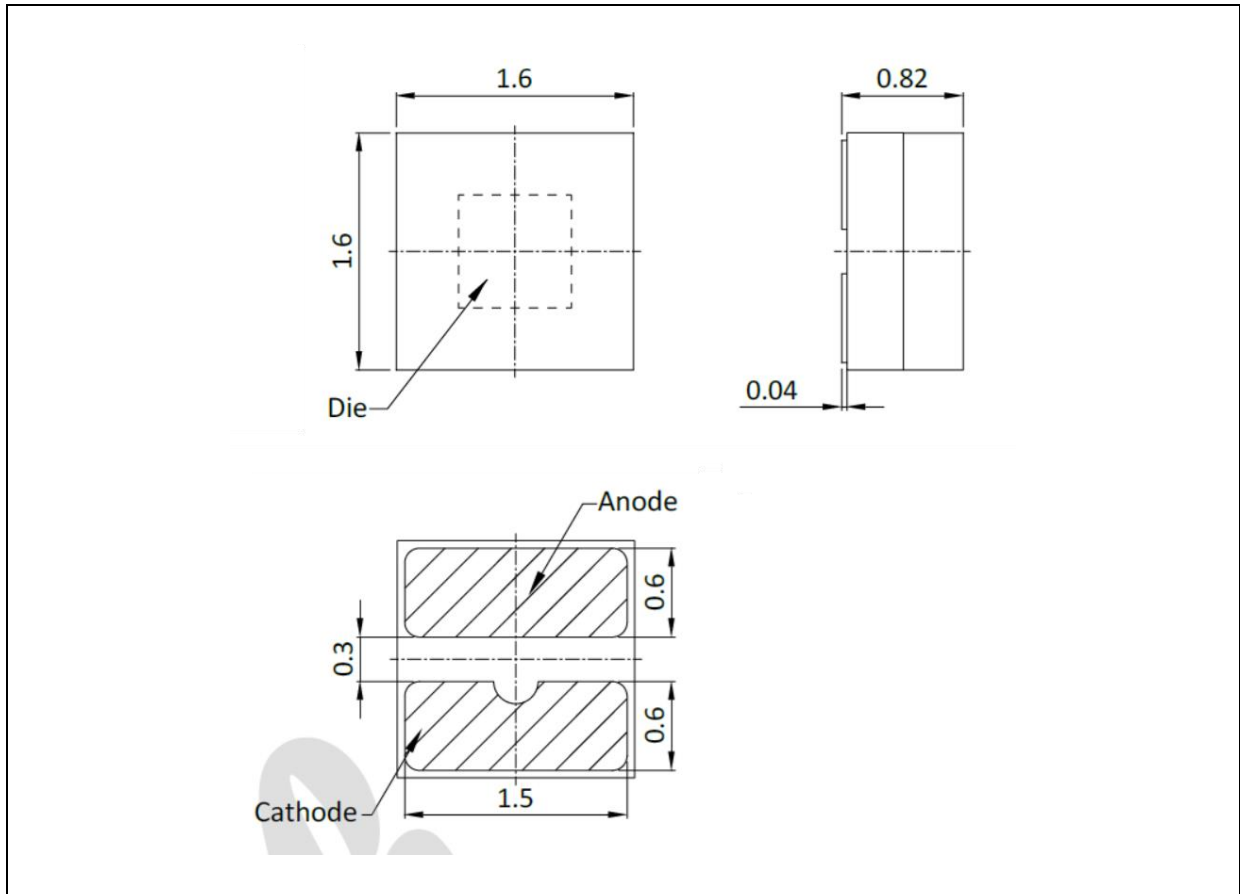

1. All dimensions are in millimetre (mm).
2. Tolerance $\pm 0.05\text{mm}$, unless otherwise noted.

Recommended Soldering Pad Dimension:

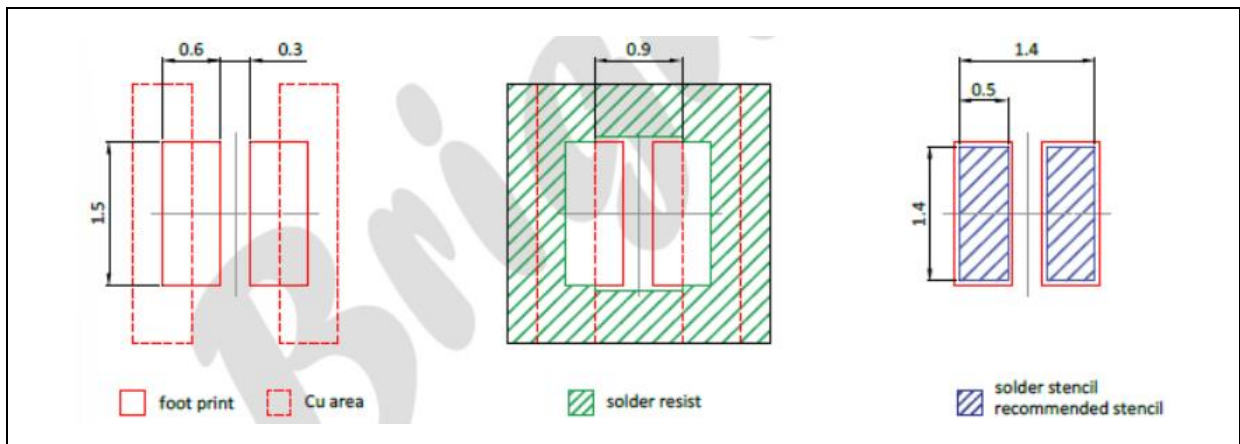

1. Dimensions are in millimetre (mm).
2. Tolerance $\pm 0.12\text{mm}$ with angle tolerance $\pm 0.5^\circ$.

BINNING GROUPS:

 Forward Voltage Classifications ($I_F=1A$, $t_p=10ms$):

Code	Min.	Max.	Unit
LP	2.9	3.6	V

 Radiant Power Classifications ($I_F=1A$, $t_p=10ms$):

Code	Min.	Max.	Unit
PB0A	1000	1200	mW
PB2A	1200	1400	

 Peak Wavelength Classifications ($I_F=1A$, $t_p=10ms$):

Code	Min.	Max.	Unit
F3	840	870	nm

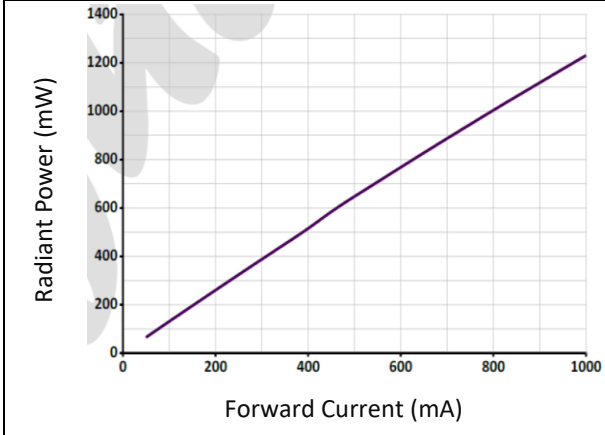
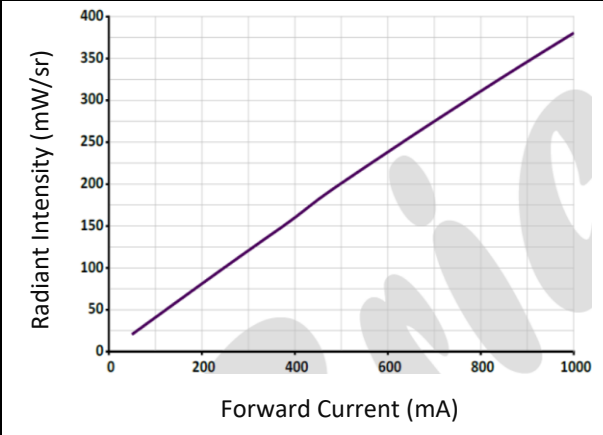
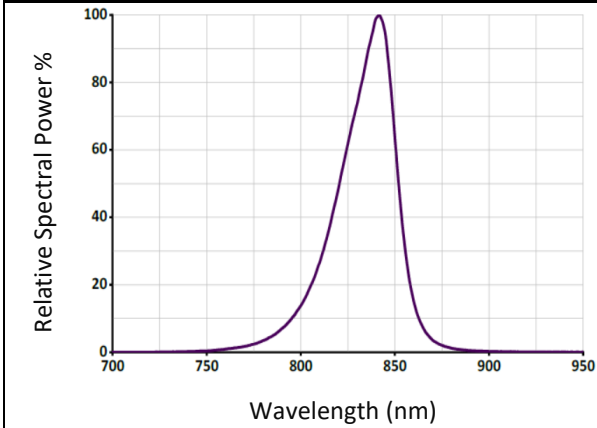
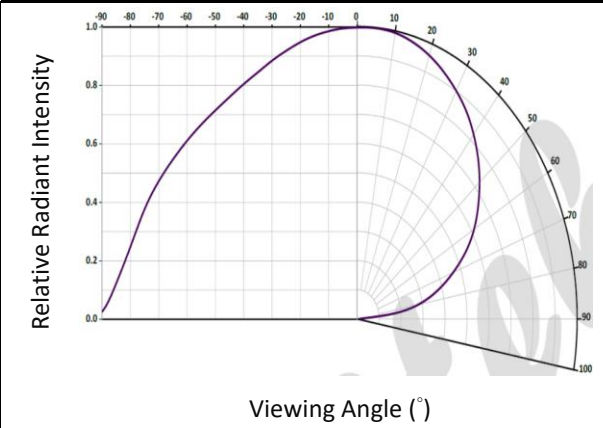
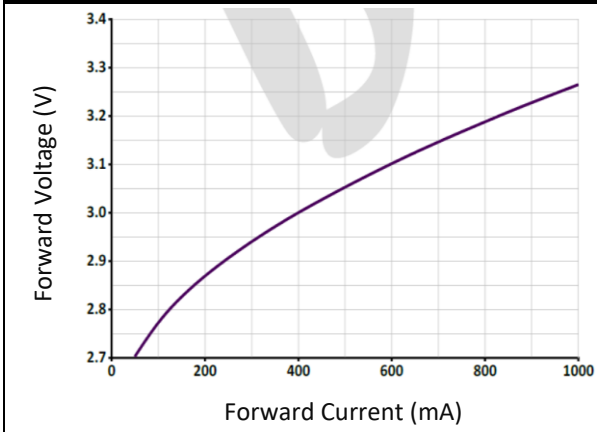
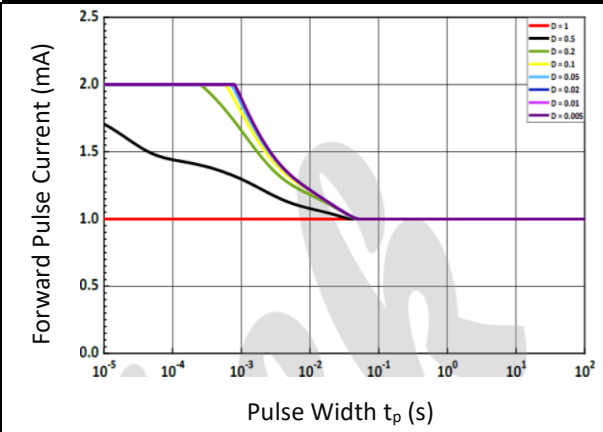
ELECTRO-OPTICAL CHARACTERISTICS:
Radiant Power v.s. Forward Current

Radiant Intensity v.s. Forward Current

Relative Spectral Power v.s. Wavelength

Directive Radiation

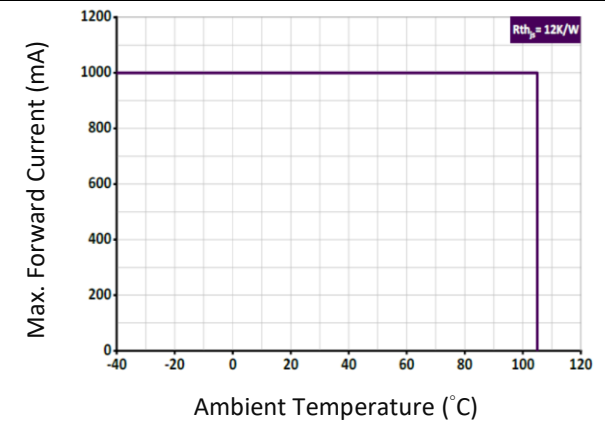
Forward Current v.s. Forward Voltage

Permissible Pulse Handling Capability
 $IF=f(t_p)$; $D=Duty$; $T_{amax}=85^\circ$

ELECTRO-OPTICAL CHARACTERISTICS:

Permissible Forward Current

$$I_{Fmax}=f(T_s); R_{thjs}=12K/W$$



RECOMMENDED SOLDERING PROFILE:

Reflow Lead-free Solder:

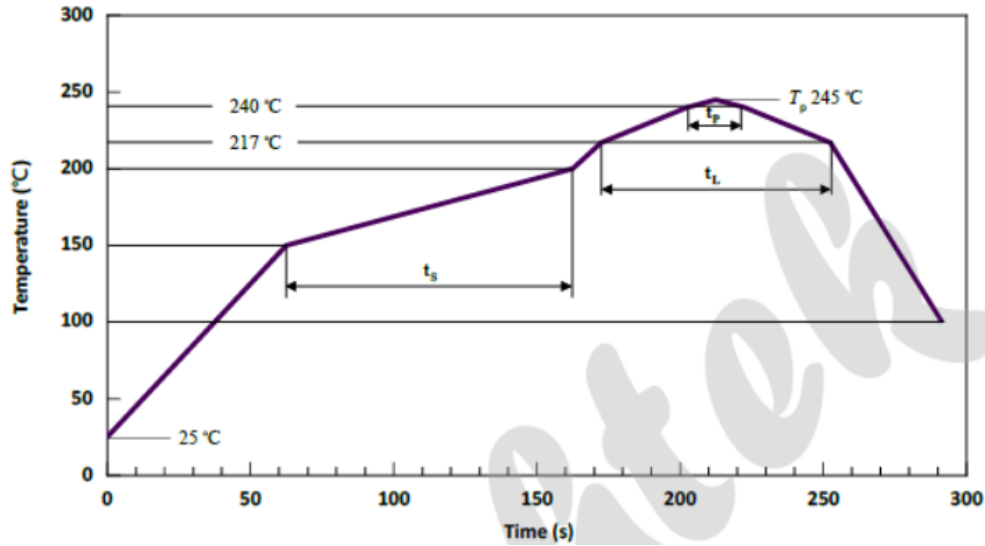

Profile Feature	Symbol	Pb-Free (SnAgCu) Assembly			Unit
		Minimum	Recommendation	Maximum	
Ramp-up rate to preheat 25 °C to 150 °C			2	3	K/s
Time t_s T_{smin} to T_{smax}	t_s	60	100	120	s
Ramp-up rate to peak T_{smax} to T_p			2	3	K/s
Liquidus temperature	T_L		217		°C
Time above liquidus temperature	t_L		80	100	s
Peak temperature	T_p		245	260	°C
Time within 5 °C of the specified peak temperature $T_p - 5$ K	T_p	10	20	30	s
Ramp-down Rate T_p to 100 °C			3	4	K/s
Time 25 °C to T_p				480	s

Note:

1. Maximum reflow soldering: 2 times.
2. The recommended soldering temperature is 240°C. The maximum soldering temperature should be limited to 245°C.
3. Before, during, and after soldering, should not apply stress on the components and PCB board.

PACKING SPECIFICATION:

Reel Dimension:

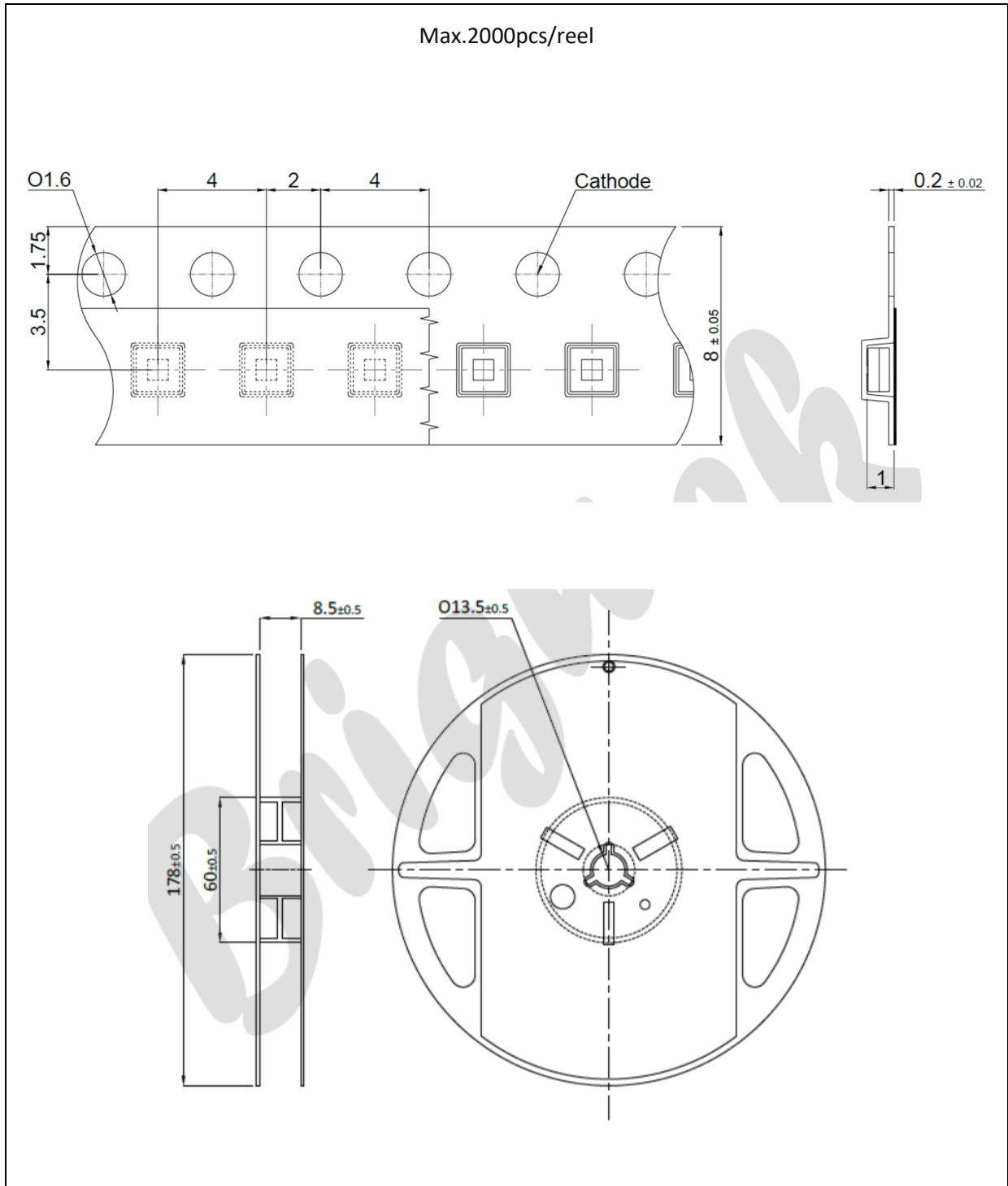

PRECAUTIONS OF USE:

Storage:

It is recommended to store the products in the following conditions:

- Humidity: 60% R.H. Max.
- Temperature: 5°C~30°C (41°F ~86°F).

Shelf life in sealed bag: 12 months at 5°C~30°C and <60% R.H.

Once the package is opened, the products should be used within a week. Otherwise, they should be kept in a damp-proof box with desiccating agent <10% R.H. and apply baking before use.

Baking:

It is recommended to bake the LED before soldering if the pack has been unsealed for longer than 24hrs. The suggested baking conditions are as followings:

- 60±3°C x 24hrs and <5%RH, taped / reel package.

It's normal to see slight color fading of carrier (light yellow) after baking in process.

Testing Circuit:



Must apply resistor(s) for protection (over current proof).

Cleaning:

Use alcohol-based cleaning solvents such as isopropyl alcohol to clean the LED carrier / package. Avoid putting any stress force directly on to the LED lens.

ESD (Electrostatic Discharge):

Static Electricity or power surge will damage the LED. Use of a conductive wrist band or anti-electrosatic glove is recommended when handling the LED all time. All devices, equipment, machinery, work tables, and storage racks must be properly grounded.

In the events of manual working in process, make sure the devices are well protected from ESD at any time.

REVISION RECORD:

Version	Date	Summary of Revision
A1.0	06/08/2024	Datasheet set-up.