



BRIGHTTEK
BRIGHTTEK (EUROPE) LIMITED

Brighten Up The World With LED!



ISO/TS 16949:2009



BS EN ISO 14001:2004



QC 080000 IECQ HSPM

PRODUCT DATASHEET



- ▶ Ceramic SMD
- ▶ 1616 1.7t Series
- ▶ Infrared (IR) 940nm

NOF66S37



Release Date: 06 August 2024 Version: A1.0



1616 1.71t Series

RoHS Compliant



**AUTOMOTIVE
AEC-Q102**

FEATURES:

- **Package:** Ceramic Dual Junction SMT Package
- **Forward Current:** 1A
- **Forward Voltage (typ.):** 3.3V
- **Radiant Power (typ.):** 1400mW@1A
- **Radiant Intensity (typ.):** 820mW/sr@1A
- **Colour:** Infrared (IR)
- **Peak Wavelength (typ.):** 940nm
- **Viewing Angle:** 80°
- **Materials:**
 - Resin: Silicon (Water Clear)
- **Operating Temperature:** -40~+105°C
- **Storage Temperature:** -40~+105°C
- **Grouping Parameters:**
 - Forward Voltage
 - Radiant Power
 - Peak Wavelength
- **Soldering Methods:** Reflow
- **MSL Level:** MSL 1 according to J-STD020
- **Corrosion Robustness Class:** A
- **Packing:** 8mm tape with max.2000pcs /reel, ø178mm (7")

APPLICATIONS:

- Automotive
- Security Camera
- Motion Detection
- Night Viewer
- Surveillance
- Data Communication
- Facial Recognition
- Gesture Recognition

CHARACTERISTICS:

Absolute Maximum Characteristics (Ta=25°C)

Parameter	Symbol	Ratings	Unit
DC Forward Current	I _F	1	A
Pulse Forward Current	I _{PF}	2	A
Power Consumption	P _{tot}	3.6	W
Reverse Voltage	V _R	5	V
Reverse Current @5V	I _R	10	μA
Junction Temperature	T _j	145	°C
Thermal Resistance Junction to Solder Point	R _{th}	typ. 9 max. 12	K/W
Electrostatic Discharge (HBM: MIL-STD-883 C 2)	ESD	2	kV
Operating Temperature	T _{OPR}	-40~+105	°C
Storage Temperature	T _{STG}	-40~+105	°C
Soldering Temperature	T _{SOL}	245	°C

1. When drive on maximum current, Junction temperature must be kept below 145°C.

Electrical & Optical Characteristics (Ta=25°C, I_F=1A, t_p=10ms)

Parameter	Symbol	Values			Unit	Test Condition
		Min.	Typ.	Max.		
Forward Voltage	V _F	2.8	3.3	3.6	V	I _F =1A
Radiant Power	Φ _e	1200	1400	1600	mW	I _F =1A
Radiant Intensity	I _e	720	820	920	mW/sr	I _F =1A
Peak Wavelength	λ _P	---	940	---	nm	I _F =1A
Spectral Bandwidth	Δλ	---	35	---	nm	I _F =1A
Viewing Angle	2θ _{1/2}	---	80	---	deg	I _F =1A

2. Radiant Power (P_o) ±10%, Forward Voltage (V_F) ±0.1V, Viewing angle(2θ_{1/2}) ±10°

OUTLINE DIMENSION:

Package Dimension:

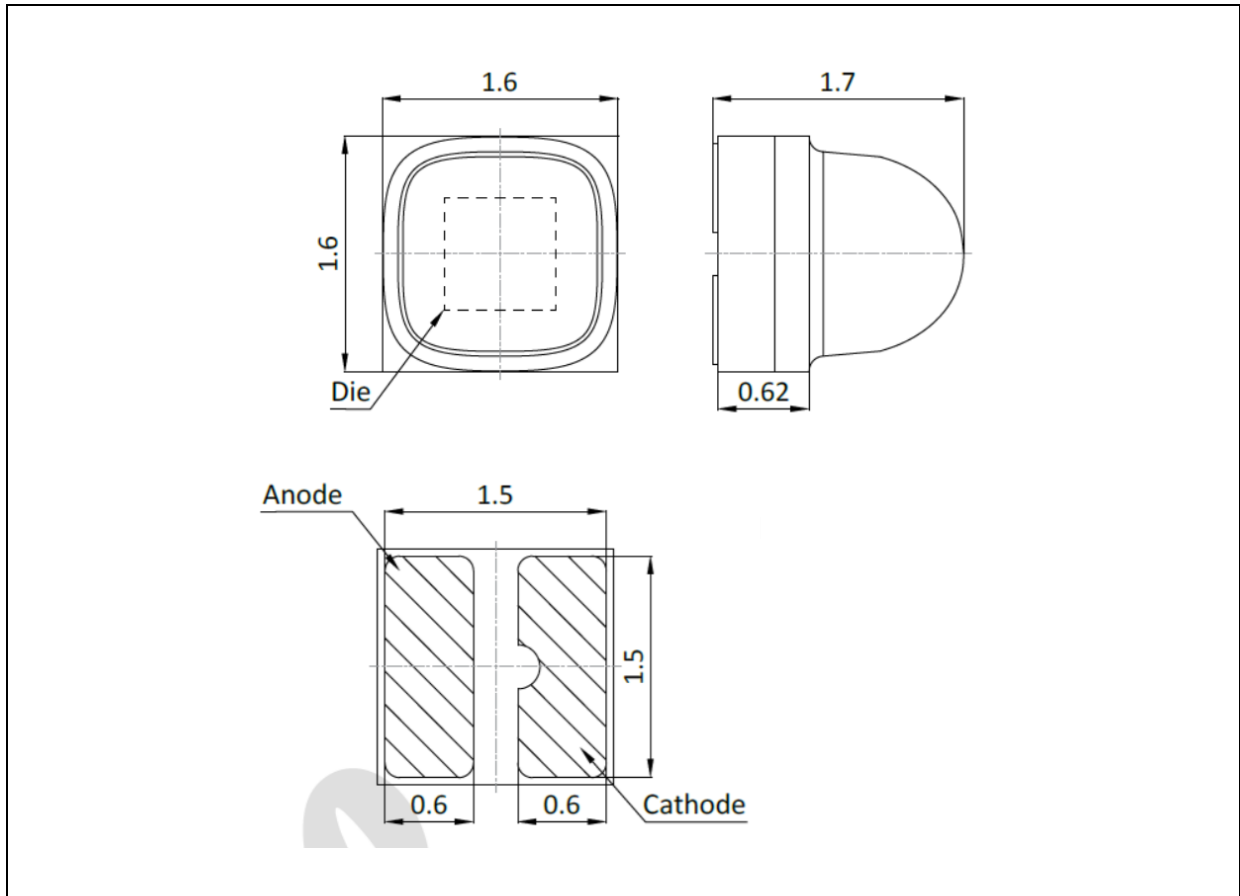

1. All dimensions are in millimetre (mm).
2. Tolerance $\pm 0.05\text{mm}$, unless otherwise noted.

Recommended Soldering Pad Dimension:

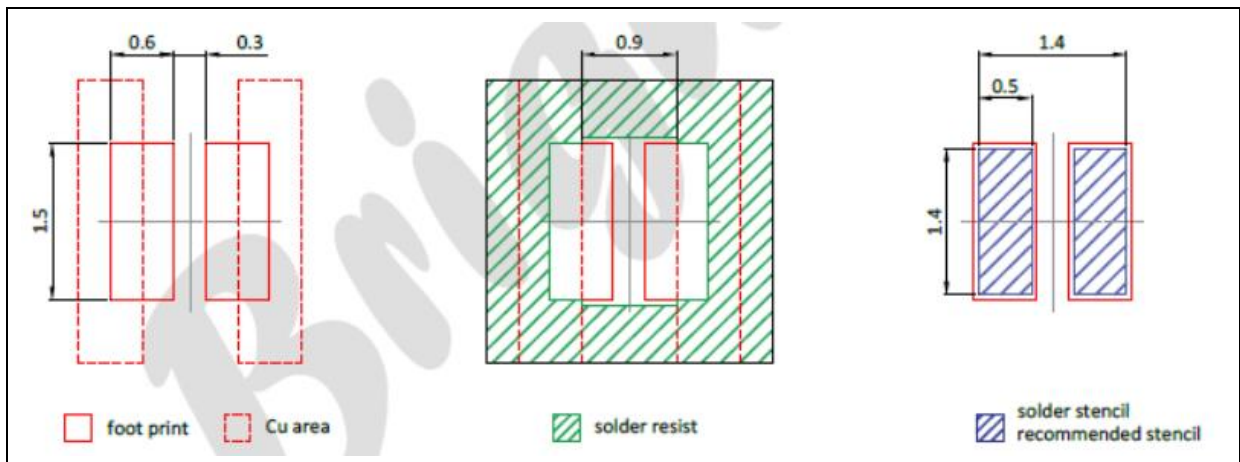

1. Dimensions are in millimetre (mm).
2. Tolerance $\pm 0.12\text{mm}$ with angle tolerance $\pm 0.5^\circ$.

BINNING GROUPS:

 Forward Voltage Classifications ($I_F=1A$, $t_p=10ms$):

Code	Min.	Max.	Unit
KN	2.8	3.6	V

 Radiant Power Classifications ($I_F=1A$, $t_p=10ms$):

Code	Min.	Max.	Unit
PB2A	1200	1400	mW
PB4A	1400	1600	

 Peak Wavelength Classifications ($I_F=1A$, $t_p=10ms$):

Code	Min.	Max.	Unit
F1	930	950	nm

ELECTRO-OPTICAL CHARACTERISTICS:

Radiant Power v.s. Forward Current

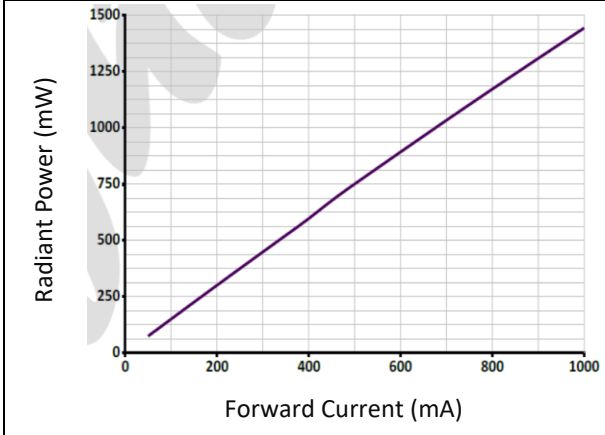

Radiant Intensity v.s. Forward Current

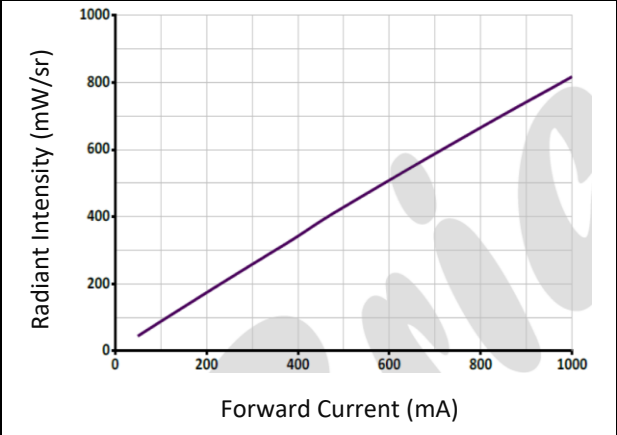

Relative Spectral Power v.s. Wavelength

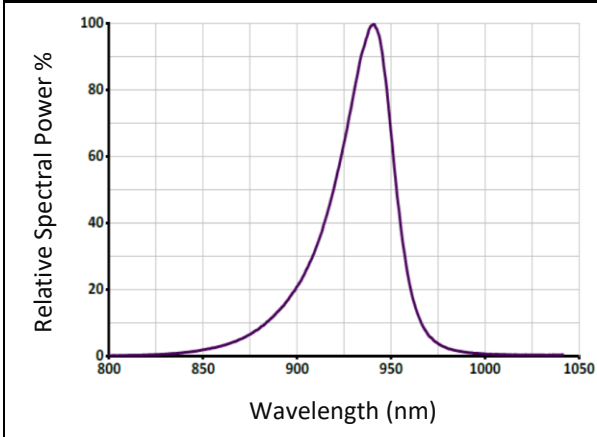

Directive Radiation

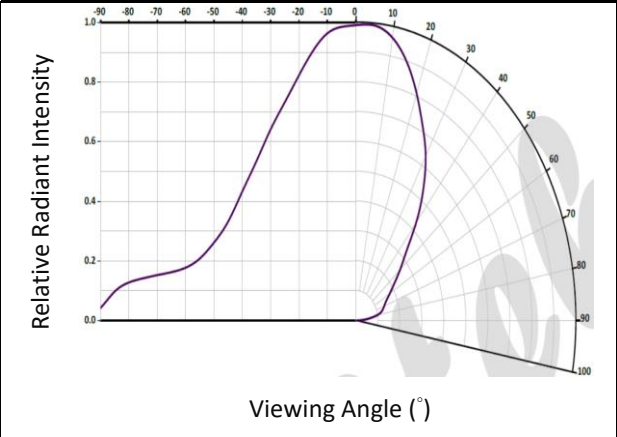

Forward Current v.s. Forward Voltage

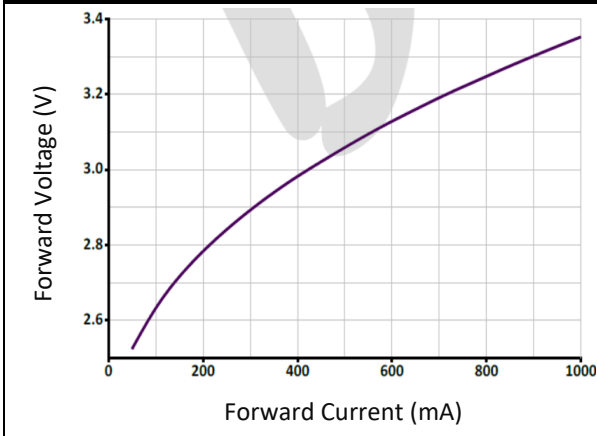

Permissible Pulse Handling Capability
 $IF=f(t_p)$; $D=Duty$; $T_{amax}=85^\circ$

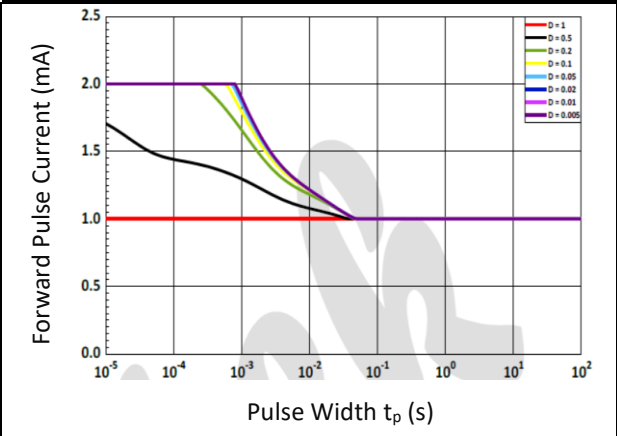

ELECTRO-OPTICAL CHARACTERISTICS:

Permissible Forward Current

$$I_{Fmax}=f(T_s); R_{thjs}=12K/W$$

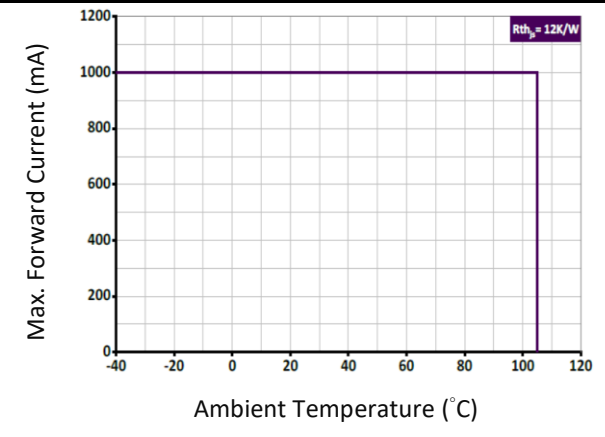



RECOMMENDED SOLDERING PROFILE:

Reflow Lead-free Solder:

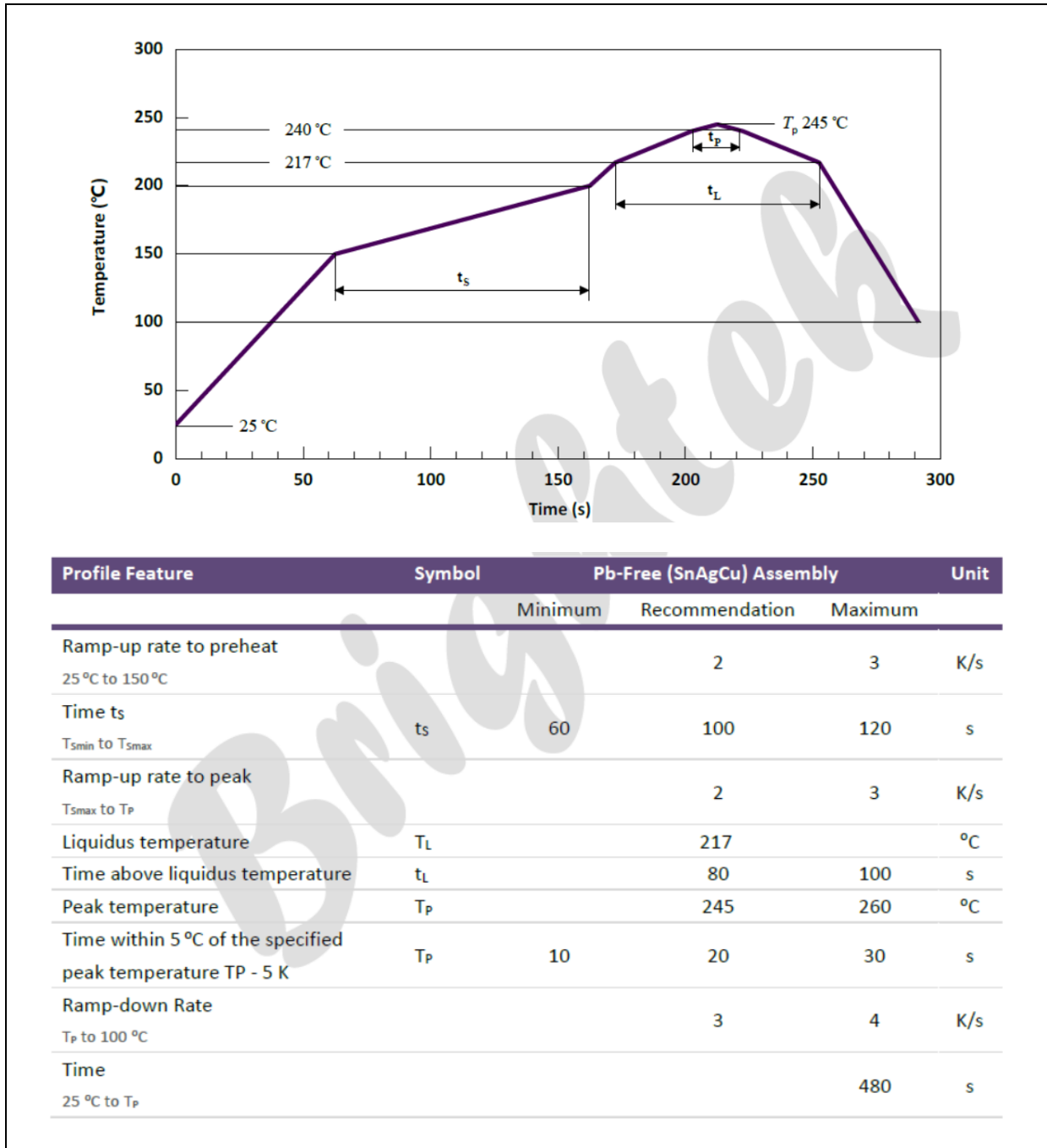

Note:

1. Maximum reflow soldering: 2 times.
2. Recommended soldering temperature is 240°C. The maximum soldering temperature should be limited to 245°C.
3. Before, during, and after soldering, should not apply stress on the components and PCB board.

PACKING SPECIFICATION:

Reel Dimension:

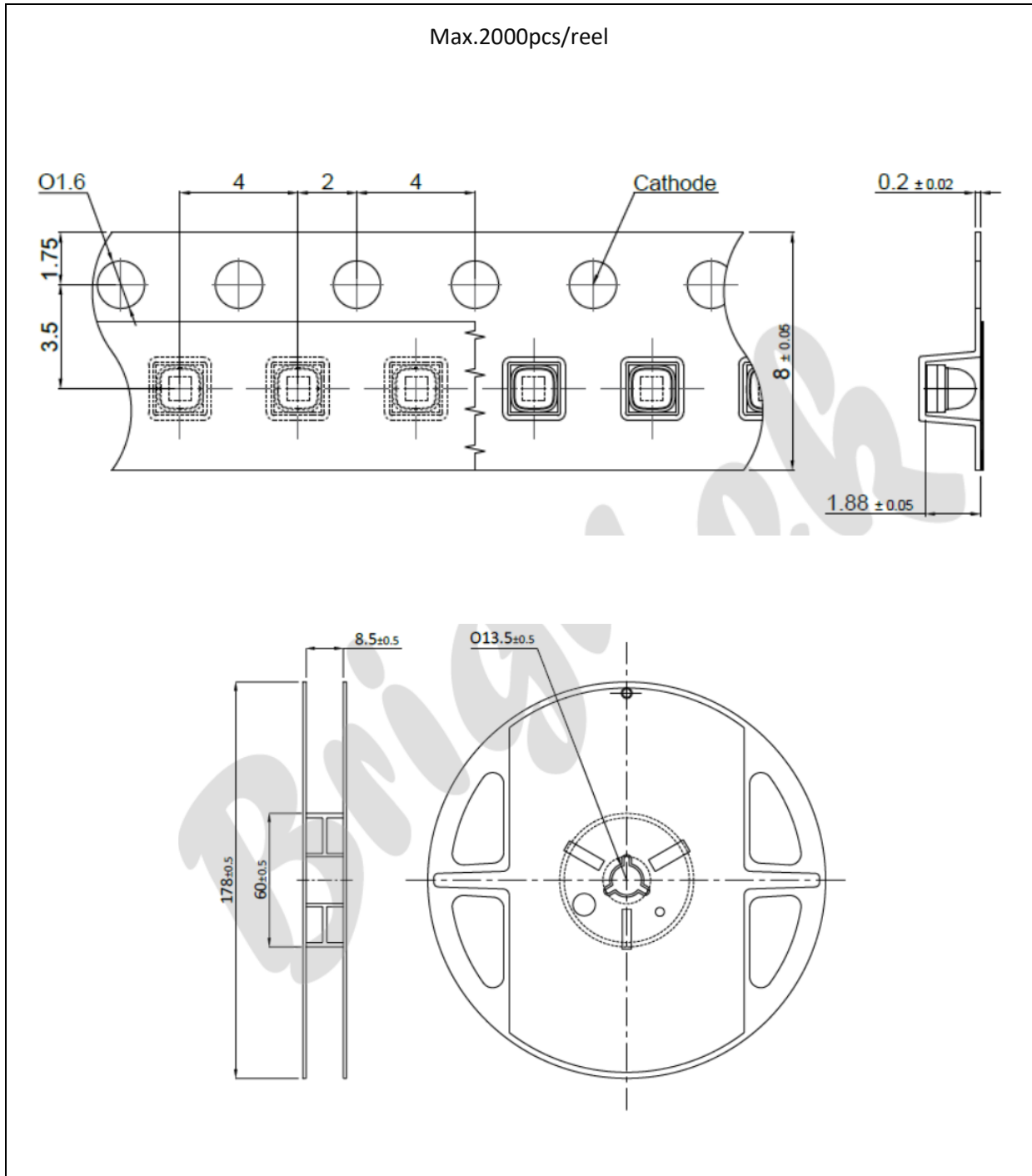

PRECAUTIONS OF USE:

Storage:

It is recommended to store the products in the following conditions:

- Humidity: 60% R.H. Max.
- Temperature: 5°C~30°C (41°F ~86°F).

Shelf life in sealed bag: 12 months at 5°C~30°C and <60% R.H.

Once the package is opened, the products should be used within a week. Otherwise, they should be kept in a damp-proof box with desiccating agent <10% R.H. and apply baking before use.

Baking:

It is recommended to bake the LED before soldering if the pack has been unsealed for longer than 24hrs. The suggested baking conditions are as followings:

- 60±3°C x 24hrs and <5%RH, taped / reel package.

It's normal to see slight color fading of carrier (light yellow) after baking in process.

Testing Circuit:



Must apply resistor(s) for protection (over current proof).

Cleaning:

Use alcohol-based cleaning solvents such as isopropyl alcohol to clean the LED carrier / package. Avoid putting any stress force directly on to the LED lens.

ESD (Electrostatic Discharge):

Static Electricity or power surge will damage the LED. Use of a conductive wrist band or anti-electrostatic glove is recommended when handling the LED all time. All devices, equipment, machinery, work tables, and storage racks must be properly grounded.

In the events of manual working in process, make sure the devices are well protected from ESD at any time.

REVISION RECORD:

Version	Date	Summary of Revision
A1.0	06/08/2024	Datasheet set-up.